

Chapter 3

1. **THINK** In this problem we're given the magnitude and direction of a vector in two dimensions, and asked to calculate its x - and y -components.

EXPRESS The x - and the y - components of a vector \vec{a} lying in the xy plane are given by

$$a_x = a \cos \theta, \quad a_y = a \sin \theta$$

where $a = |\vec{a}| = \sqrt{a_x^2 + a_y^2}$ is the magnitude and $\theta = \tan^{-1}(a_y / a_x)$ is the angle between \vec{a} and the positive x axis. Given that $\theta = 250^\circ$, we see that the vector is in the third quadrant, and we expect both the x - and the y -components of \vec{a} to be negative.

ANALYZE (a) The x component of \vec{a} is

$$a_x = a \cos \theta = (7.3 \text{ m}) \cos 250^\circ = -2.50 \text{ m},$$

(b) and the y component is $a_y = a \sin \theta = (7.3 \text{ m}) \sin 250^\circ = -6.86 \text{ m} \approx -6.9 \text{ m}$. The results are depicted in the figure below:

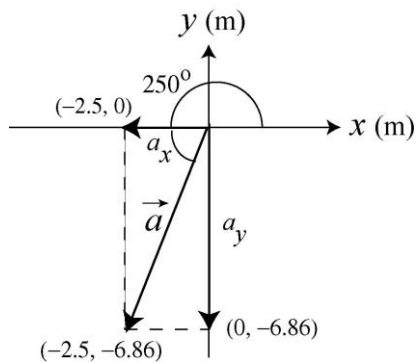

LEARN In considering the variety of ways to compute these, we note that the vector is 70° below the $-x$ axis, so the components could also have been found from

$$a_x = -(7.3 \text{ m}) \cos 70^\circ = -2.50 \text{ m}, \quad a_y = -(7.3 \text{ m}) \sin 70^\circ = -6.86 \text{ m}.$$

Similarly, we note that the vector is 20° to the left from the $-y$ axis, so one could also achieve the same results by using

$$a_x = -(7.3 \text{ m}) \sin 20^\circ = -2.50 \text{ m}, \quad a_y = -(7.3 \text{ m}) \cos 20^\circ = -6.86 \text{ m}.$$

As a consistency check, we note that $\sqrt{a_x^2 + a_y^2} = \sqrt{(-2.50 \text{ m})^2 + (-6.86 \text{ m})^2} = 7.3 \text{ m}$ and $\tan^{-1}(a_y/a_x) = \tan^{-1}[(-6.86 \text{ m})/(-2.50 \text{ m})] = 250^\circ$, which are indeed the values given in the problem statement.

2. (a) With $r = 15 \text{ m}$ and $\theta = 30^\circ$, the x component of \vec{r} is given by

$$r_x = r \cos \theta = (15 \text{ m}) \cos 30^\circ = 13 \text{ m}.$$

(b) Similarly, the y component is given by $r_y = r \sin \theta = (15 \text{ m}) \sin 30^\circ = 7.5 \text{ m}$.

3. **THINK** In this problem we're given the x - and y -components a vector \vec{A} in two dimensions, and asked to calculate its magnitude and direction.

EXPRESS A vector \vec{A} can be represented in the *magnitude-angle* notation (A, θ) , where

$$A = \sqrt{A_x^2 + A_y^2}$$

is the magnitude and

$$\theta = \tan^{-1} \left(\frac{A_y}{A_x} \right)$$

is the angle \vec{A} makes with the positive x axis. Given that $A_x = -25.0 \text{ m}$ and $A_y = 40.0 \text{ m}$, the above formulas can be readily used to calculate A and θ .

ANALYZE (a) The magnitude of the vector \vec{A} is

$$A = \sqrt{A_x^2 + A_y^2} = \sqrt{(-25.0 \text{ m})^2 + (40.0 \text{ m})^2} = 47.2 \text{ m}$$

(b) Recalling that $\tan \theta = \tan(\theta + 180^\circ)$,

$$\tan^{-1} [(40.0 \text{ m})/(-25.0 \text{ m})] = -58^\circ \text{ or } 122^\circ.$$

Noting that the vector is in the second quadrant (by the signs of its x and y components) we see that 122° is the correct answer. The results are depicted in the figure to the right.

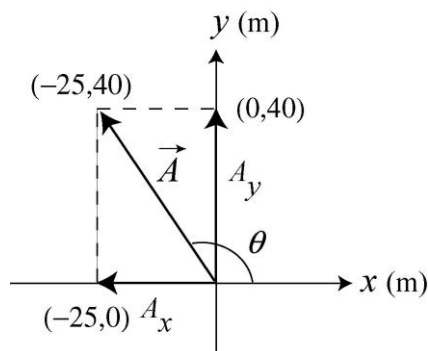

LEARN We can check our answers by noting that the x - and the y - components of \vec{A} can be written as

$$A_x = A \cos \theta, \quad A_y = A \sin \theta.$$

Substituting the results calculated above, we obtain

$$A_x = (47.2 \text{ m})\cos 122^\circ = -25.0 \text{ m}, \quad A_y = (47.2 \text{ m})\sin 122^\circ = +40.0 \text{ m}$$

which indeed are the values given in the problem statement.

4. The angle described by a full circle is $360^\circ = 2\pi \text{ rad}$, which is the basis of our conversion factor.

$$(a) \quad 20.0^\circ = (20.0^\circ) \frac{2\pi \text{ rad}}{360^\circ} = 0.349 \text{ rad}.$$

$$(b) \quad 50.0^\circ = (50.0^\circ) \frac{2\pi \text{ rad}}{360^\circ} = 0.873 \text{ rad}.$$

$$(c) \quad 100^\circ = (100^\circ) \frac{2\pi \text{ rad}}{360^\circ} = 1.75 \text{ rad}.$$

$$(d) \quad 0.330 \text{ rad} = (0.330 \text{ rad}) \frac{360^\circ}{2\pi \text{ rad}} = 18.9^\circ.$$

$$(e) \quad 2.10 \text{ rad} = (2.10 \text{ rad}) \frac{360^\circ}{2\pi \text{ rad}} = 120^\circ.$$

$$(f) \quad 7.70 \text{ rad} = (7.70 \text{ rad}) \frac{360^\circ}{2\pi \text{ rad}} = 441^\circ.$$

5. The vector sum of the displacements \vec{d}_{storm} and \vec{d}_{new} must give the same result as its originally intended displacement $\vec{d}_o = (120 \text{ km})\hat{j}$ where east is \hat{i} , north is \hat{j} . Thus, we write

$$\vec{d}_{\text{storm}} = (100 \text{ km})\hat{i}, \quad \vec{d}_{\text{new}} = A\hat{i} + B\hat{j}.$$

(a) The equation $\vec{d}_{\text{storm}} + \vec{d}_{\text{new}} = \vec{d}_o$ readily yields $A = -100 \text{ km}$ and $B = 120 \text{ km}$. The magnitude of \vec{d}_{new} is therefore equal to $|\vec{d}_{\text{new}}| = \sqrt{A^2 + B^2} = 156 \text{ km}$.

(b) The direction is

$$\tan^{-1}(B/A) = -50.2^\circ \text{ or } 180^\circ + (-50.2^\circ) = 129.8^\circ.$$

We choose the latter value since it indicates a vector pointing in the second quadrant, which is what we expect here. The answer can be phrased several equivalent ways: 129.8° counterclockwise from east, or 39.8° west from north, or 50.2° north from west.

6. (a) The height is $h = d \sin \theta$, where $d = 12.5 \text{ m}$ and $\theta = 20.0^\circ$. Therefore, $h = 4.28 \text{ m}$.

(b) The horizontal distance is $d \cos \theta = 11.7 \text{ m}$.

7. (a) The vectors should be parallel to achieve a resultant 7 m long (the unprimed case shown below),

(b) anti-parallel (in opposite directions) to achieve a resultant 1 m long (primed case shown),

(c) and perpendicular to achieve a resultant $\sqrt{3^2 + 4^2} = 5$ m long (the double-primed case shown).

In each sketch, the vectors are shown in a “head-to-tail” sketch but the resultant is not shown. The resultant would be a straight line drawn from beginning to end; the beginning is indicated by A (with or without primes, as the case may be) and the end is indicated by B .

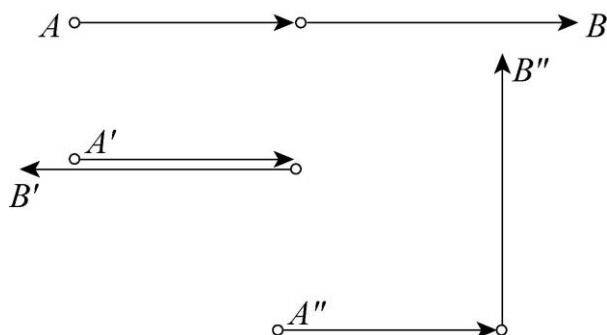

8. We label the displacement vectors \vec{A} , \vec{B} , and \vec{C} (and denote the result of their vector sum as \vec{r}). We choose *east* as the \hat{i} direction (+ x direction) and *north* as the \hat{j} direction (+ y direction). All distances are understood to be in kilometers.

(a) The vector diagram representing the motion is shown next:

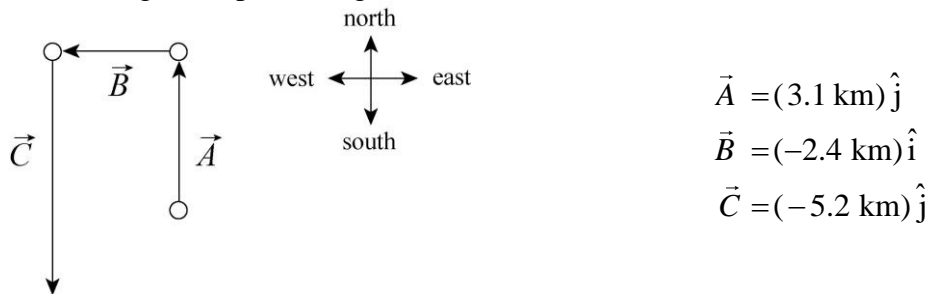

(b) The final point is represented by

$$\vec{r} = \vec{A} + \vec{B} + \vec{C} = (-2.4 \text{ km}) \hat{i} + (-2.1 \text{ km}) \hat{j}$$

whose magnitude is

$$|\vec{r}| = \sqrt{(-2.4 \text{ km})^2 + (-2.1 \text{ km})^2} \approx 3.2 \text{ km} .$$

(c) There are two possibilities for the angle:

$$\theta = \tan^{-1}\left(\frac{-2.1 \text{ km}}{-2.4 \text{ km}}\right) = 41^\circ, \text{ or } 221^\circ.$$

We choose the latter possibility since \vec{r} is in the third quadrant. It should be noted that many graphical calculators have polar \leftrightarrow rectangular “shortcuts” that automatically produce the correct answer for angle (measured counterclockwise from the $+x$ axis). We may phrase the angle, then, as 221° counterclockwise from East (a phrasing that sounds peculiar, at best) or as 41° south from west or 49° west from south. The resultant \vec{r} is not shown in our sketch; it would be an arrow directed from the “tail” of \vec{A} to the “head” of \vec{C} .

9. All distances in this solution are understood to be in meters.

$$(a) \vec{a} + \vec{b} = [4.0 + (-1.0)]\hat{i} + [(-3.0) + 1.0]\hat{j} + (1.0 + 4.0)\hat{k} = (3.0\hat{i} - 2.0\hat{j} + 5.0\hat{k}) \text{ m.}$$

$$(b) \vec{a} - \vec{b} = [4.0 - (-1.0)]\hat{i} + [(-3.0) - 1.0]\hat{j} + (1.0 - 4.0)\hat{k} = (5.0\hat{i} - 4.0\hat{j} - 3.0\hat{k}) \text{ m.}$$

(c) The requirement $\vec{a} - \vec{b} + \vec{c} = 0$ leads to $\vec{c} = \vec{b} - \vec{a}$, which we note is the opposite of what we found in part (b). Thus, $\vec{c} = (-5.0\hat{i} + 4.0\hat{j} + 3.0\hat{k}) \text{ m.}$

10. The x , y , and z components of $\vec{r} = \vec{c} + \vec{d}$ are, respectively,

$$(a) r_x = c_x + d_x = 7.4 \text{ m} + 4.4 \text{ m} = 12 \text{ m},$$

$$(b) r_y = c_y + d_y = -3.8 \text{ m} - 2.0 \text{ m} = -5.8 \text{ m}, \text{ and}$$

$$(c) r_z = c_z + d_z = -6.1 \text{ m} + 3.3 \text{ m} = -2.8 \text{ m.}$$

11. **THINK** This problem involves the addition of two vectors \vec{a} and \vec{b} . We want to find the magnitude and direction of the resulting vector.

EXPRESS In two dimensions, a vector \vec{a} can be written as, in unit vector notation,

$$\vec{a} = a_x\hat{i} + a_y\hat{j}.$$

Similarly, a second vector \vec{b} can be expressed as $\vec{b} = b_x\hat{i} + b_y\hat{j}$. Adding the two vectors gives

$$\vec{r} = \vec{a} + \vec{b} = (a_x + b_x)\hat{i} + (a_y + b_y)\hat{j} = r_x\hat{i} + r_y\hat{j}$$

ANALYZE (a) Given that $\vec{a} = (4.0 \text{ m})\hat{i} + (3.0 \text{ m})\hat{j}$ and $\vec{b} = (-13.0 \text{ m})\hat{i} + (7.0 \text{ m})\hat{j}$, we find the x and the y components of \vec{r} to be

$$r_x = a_x + b_x = (4.0 \text{ m}) + (-13 \text{ m}) = -9.0 \text{ m}$$

$$r_y = a_y + b_y = (3.0 \text{ m}) + (7.0 \text{ m}) = 10.0 \text{ m}.$$

Thus $\vec{r} = (-9.0\text{m})\hat{i} + (10\text{m})\hat{j}$.

(b) The magnitude of \vec{r} is $r = |\vec{r}| = \sqrt{r_x^2 + r_y^2} = \sqrt{(-9.0 \text{ m})^2 + (10 \text{ m})^2} = 13 \text{ m}$.

(c) The angle between the resultant and the $+x$ axis is given by

$$\theta = \tan^{-1}\left(\frac{r_y}{r_x}\right) = \tan^{-1}\left(\frac{10.0 \text{ m}}{-9.0 \text{ m}}\right) = -48^\circ \text{ or } 132^\circ.$$

Since the x component of the resultant is negative and the y component is positive, characteristic of the second quadrant, we find the angle is 132° (measured counterclockwise from $+x$ axis).

LEARN The addition of the two vectors is depicted in the figure below (not to scale). Indeed, since $r_x < 0$ and $r_y > 0$, we expect \vec{r} to be in the second quadrant.

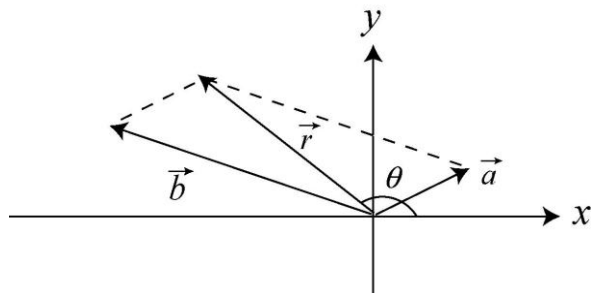

12. We label the displacement vectors \vec{A} , \vec{B} , and \vec{C} (and denote the result of their vector sum as \vec{r}). We choose *east* as the \hat{i} direction ($+x$ direction) and *north* as the \hat{j} direction ($+y$ direction). We note that the angle between \vec{C} and the x axis is 60° . Thus,

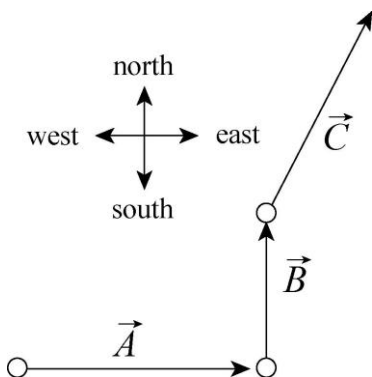

$$\vec{A} = (50 \text{ km})\hat{i}$$

$$\vec{B} = (30 \text{ km})\hat{j}$$

$$\vec{C} = (25 \text{ km}) \cos(60^\circ) \hat{i} + (25 \text{ km}) \sin(60^\circ) \hat{j}$$

(a) The total displacement of the car from its initial position is represented by

$$\vec{r} = \vec{A} + \vec{B} + \vec{C} = (62.5 \text{ km})\hat{i} + (51.7 \text{ km})\hat{j}$$

which means that its magnitude is

$$|\vec{r}| = \sqrt{(62.5 \text{ km})^2 + (51.7 \text{ km})^2} = 81 \text{ km.}$$

(b) The angle (counterclockwise from $+x$ axis) is $\tan^{-1}(51.7 \text{ km}/62.5 \text{ km}) = 40^\circ$, which is to say that it points 40° north of east. Although the resultant \vec{r} is shown in our sketch, it would be a direct line from the “tail” of \vec{A} to the “head” of \vec{C} .

13. We find the components and then add them (as scalars, not vectors). With $d = 3.40$ km and $\theta = 35.0^\circ$ we find $d \cos \theta + d \sin \theta = 4.74$ km.

14. (a) Summing the x components, we have

$$20 \text{ m} + b_x - 20 \text{ m} - 60 \text{ m} = -140 \text{ m,}$$

which gives $b_x = -80$ m.

(b) Summing the y components, we have

$$60 \text{ m} - 70 \text{ m} + c_y - 70 \text{ m} = 30 \text{ m,}$$

which implies $c_y = 110$ m.

(c) Using the Pythagorean theorem, the magnitude of the overall displacement is given by

$$\sqrt{(-140 \text{ m})^2 + (30 \text{ m})^2} \approx 143 \text{ m.}$$

(d) The angle is given by $\tan^{-1}(30/(-140)) = -12^\circ$, (which would be 12° measured clockwise from the $-x$ axis, or 168° measured counterclockwise from the $+x$ axis).

15. **THINK** This problem involves the addition of two vectors \vec{a} and \vec{b} in two dimensions. We’re asked to find the components, magnitude and direction of the resulting vector.

EXPRESS In two dimensions, a vector \vec{a} can be written as, in unit vector notation,

$$\vec{a} = a_x \hat{i} + a_y \hat{j} = (a \cos \alpha) \hat{i} + (a \sin \alpha) \hat{j}.$$

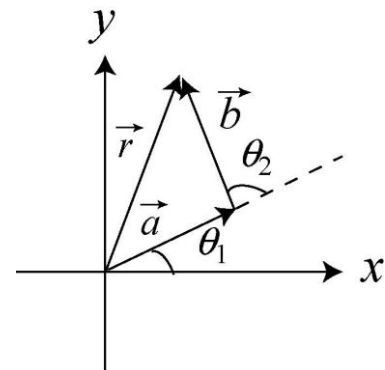

Similarly, a second vector \vec{b} can be expressed as $\vec{b} = b_x \hat{i} + b_y \hat{j} = (b \cos \beta) \hat{i} + (b \sin \beta) \hat{j}$. From the figure, we have, $\alpha = \theta_1$ and $\beta = \theta_1 + \theta_2$ (since the angles are measured from the $+x$ -axis) and the resulting vector is

$$\vec{r} = \vec{a} + \vec{b} = [a \cos \theta_1 + b \cos(\theta_1 + \theta_2)] \hat{i} + [a \sin \theta_1 + b \sin(\theta_1 + \theta_2)] \hat{j} = r_x \hat{i} + r_y \hat{j}$$

ANALYZE (a) Given that $a = b = 10$ m, $\theta_1 = 30^\circ$ and $\theta_2 = 105^\circ$, the x component of \vec{r} is

$$r_x = a \cos \theta_1 + b \cos(\theta_1 + \theta_2) = (10 \text{ m}) \cos 30^\circ + (10 \text{ m}) \cos(30^\circ + 105^\circ) = 1.59 \text{ m}$$

(b) Similarly, the y component of \vec{r} is

$$r_y = a \sin \theta_1 + b \sin(\theta_1 + \theta_2) = (10 \text{ m}) \sin 30^\circ + (10 \text{ m}) \sin(30^\circ + 105^\circ) = 12.1 \text{ m}.$$

(c) The magnitude of \vec{r} is $r = |\vec{r}| = \sqrt{(1.59 \text{ m})^2 + (12.1 \text{ m})^2} = 12.2 \text{ m}$.

(d) The angle between \vec{r} and the $+x$ -axis is

$$\theta = \tan^{-1} \left(\frac{r_y}{r_x} \right) = \tan^{-1} \left(\frac{12.1 \text{ m}}{1.59 \text{ m}} \right) = 82.5^\circ.$$

LEARN As depicted in the figure, the resultant \vec{r} lies in the first quadrant. This is what we expect. Note that the magnitude of \vec{r} can also be calculated by using law of cosine (\vec{a} , \vec{b} and \vec{r} form an isosceles triangle):

$$\begin{aligned} r &= \sqrt{a^2 + b^2 - 2ab \cos(180 - \theta_2)} = \sqrt{(10 \text{ m})^2 + (10 \text{ m})^2 - 2(10 \text{ m})(10 \text{ m}) \cos 75^\circ} \\ &= 12.2 \text{ m}. \end{aligned}$$

16. (a) $\vec{a} + \vec{b} = (3.0 \hat{i} + 4.0 \hat{j}) \text{ m} + (5.0 \hat{i} - 2.0 \hat{j}) \text{ m} = (8.0 \text{ m}) \hat{i} + (2.0 \text{ m}) \hat{j}$.

(b) The magnitude of $\vec{a} + \vec{b}$ is

$$|\vec{a} + \vec{b}| = \sqrt{(8.0 \text{ m})^2 + (2.0 \text{ m})^2} = 8.2 \text{ m}.$$

(c) The angle between this vector and the $+x$ axis is

$$\tan^{-1}[(2.0 \text{ m})/(8.0 \text{ m})] = 14^\circ.$$

(d) $\vec{b} - \vec{a} = (5.0 \hat{i} - 2.0 \hat{j}) \text{ m} - (3.0 \hat{i} + 4.0 \hat{j}) \text{ m} = (2.0 \text{ m}) \hat{i} - (6.0 \text{ m}) \hat{j}$.

(e) The magnitude of the difference vector $\vec{b} - \vec{a}$ is

$$|\vec{b} - \vec{a}| = \sqrt{(2.0 \text{ m})^2 + (-6.0 \text{ m})^2} = 6.3 \text{ m}.$$

(f) The angle between this vector and the $+x$ axis is $\tan^{-1}[(-6.0 \text{ m})/(2.0 \text{ m})] = -72^\circ$. The vector is 72° clockwise from the axis defined by \hat{i} .

17. Many of the operations are done efficiently on most modern graphical calculators using their built-in vector manipulation and rectangular \leftrightarrow polar “shortcuts.” In this solution, we employ the “traditional” methods (such as Eq. 3-6). Where the length unit is not displayed, the unit meter should be understood.

(a) Using unit-vector notation,

$$\begin{aligned}\vec{a} &= (50 \text{ m}) \cos(30^\circ) \hat{i} + (50 \text{ m}) \sin(30^\circ) \hat{j} \\ \vec{b} &= (50 \text{ m}) \cos(195^\circ) \hat{i} + (50 \text{ m}) \sin(195^\circ) \hat{j} \\ \vec{c} &= (50 \text{ m}) \cos(315^\circ) \hat{i} + (50 \text{ m}) \sin(315^\circ) \hat{j} \\ \vec{a} + \vec{b} + \vec{c} &= (30.4 \text{ m}) \hat{i} - (23.3 \text{ m}) \hat{j}.\end{aligned}$$

The magnitude of this result is $\sqrt{(30.4 \text{ m})^2 + (-23.3 \text{ m})^2} = 38 \text{ m}$.

(b) The two possibilities presented by a simple calculation for the angle between the vector described in part (a) and the $+x$ direction are $\tan^{-1}[(-23.2 \text{ m})/(30.4 \text{ m})] = -37.5^\circ$, and $180^\circ + (-37.5^\circ) = 142.5^\circ$. The former possibility is the correct answer since the vector is in the fourth quadrant (indicated by the signs of its components). Thus, the angle is -37.5° , which is to say that it is 37.5° clockwise from the $+x$ axis. This is equivalent to 322.5° counterclockwise from $+x$.

(c) We find

$$\vec{a} - \vec{b} + \vec{c} = [43.3 - (-48.3) + 35.4] \hat{i} - [25 - (-12.9) + (-35.4)] \hat{j} = (127 \hat{i} + 2.60 \hat{j}) \text{ m}$$

in unit-vector notation. The magnitude of this result is

$$|\vec{a} - \vec{b} + \vec{c}| = \sqrt{(127 \text{ m})^2 + (2.6 \text{ m})^2} \approx 1.30 \times 10^2 \text{ m}.$$

(d) The angle between the vector described in part (c) and the $+x$ axis is $\tan^{-1}(2.6 \text{ m}/127 \text{ m}) \approx 1.2^\circ$.

(e) Using unit-vector notation, \vec{d} is given by $\vec{d} = \vec{a} + \vec{b} - \vec{c} = (-40.4 \hat{i} + 47.4 \hat{j}) \text{ m}$, which has a magnitude of $\sqrt{(-40.4 \text{ m})^2 + (47.4 \text{ m})^2} = 62 \text{ m}$.

(f) The two possibilities presented by a simple calculation for the angle between the vector described in part (e) and the $+x$ axis are $\tan^{-1}(47.4/(-40.4)) = -50.0^\circ$, and $180^\circ + (-50.0^\circ) = 130^\circ$. We choose the latter possibility as the correct one since it indicates that \vec{d} is in the second quadrant (indicated by the signs of its components).

18. If we wish to use Eq. 3-5 in an unmodified fashion, we should note that the angle between \vec{C} and the $+x$ axis is $180^\circ + 20.0^\circ = 200^\circ$.

(a) The x and y components of \vec{B} are given by

$$\begin{aligned} B_x &= C_x - A_x = (15.0 \text{ m}) \cos 200^\circ - (12.0 \text{ m}) \cos 40^\circ = -23.3 \text{ m}, \\ B_y &= C_y - A_y = (15.0 \text{ m}) \sin 200^\circ - (12.0 \text{ m}) \sin 40^\circ = -12.8 \text{ m}. \end{aligned}$$

Consequently, its magnitude is $|\vec{B}| = \sqrt{(-23.3 \text{ m})^2 + (-12.8 \text{ m})^2} = 26.6 \text{ m}$.

(b) The two possibilities presented by a simple calculation for the angle between \vec{B} and the $+x$ axis are $\tan^{-1}[(-12.8 \text{ m})/(-23.3 \text{ m})] = 28.9^\circ$, and $180^\circ + 28.9^\circ = 209^\circ$. We choose the latter possibility as the correct one since it indicates that \vec{B} is in the third quadrant (indicated by the signs of its components). We note, too, that the answer can be equivalently stated as -151° .

19. (a) With \hat{i} directed forward and \hat{j} directed leftward, the resultant is $(5.00 \hat{i} + 2.00 \hat{j}) \text{ m}$. The magnitude is given by the Pythagorean theorem: $\sqrt{(5.00 \text{ m})^2 + (2.00 \text{ m})^2} = 5.385 \text{ m} \approx 5.39 \text{ m}$.

(b) The angle is $\tan^{-1}(2.00/5.00) \approx 21.8^\circ$ (left of forward).

20. The desired result is the displacement vector, in units of km, $\vec{A} = (5.6 \text{ km}), 90^\circ$ (measured counterclockwise from the $+x$ axis), or $\vec{A} = (5.6 \text{ km})\hat{j}$, where \hat{j} is the unit vector along the positive y axis (north). This consists of the sum of two displacements: during the whiteout, $\vec{B} = (7.8 \text{ km}), 50^\circ$, or

$$\vec{B} = (7.8 \text{ km})(\cos 50^\circ \hat{i} + \sin 50^\circ \hat{j}) = (5.01 \text{ km})\hat{i} + (5.98 \text{ km})\hat{j}$$

and the unknown \vec{C} . Thus, $\vec{A} = \vec{B} + \vec{C}$.

(a) The desired displacement is given by $\vec{C} = \vec{A} - \vec{B} = (-5.01 \text{ km}) \hat{i} - (0.38 \text{ km}) \hat{j}$. The magnitude is $\sqrt{(-5.01 \text{ km})^2 + (-0.38 \text{ km})^2} = 5.0 \text{ km}$.

(b) The angle is $\tan^{-1}[(-0.38 \text{ km})/(-5.01 \text{ km})] = 4.3^\circ$, south of due west.

21. Reading carefully, we see that the (x, y) specifications for each “dart” are to be interpreted as $(\Delta x, \Delta y)$ descriptions of the corresponding displacement vectors. We combine the different parts of this problem into a single exposition.

(a) Along the x axis, we have (with the centimeter unit understood)

$$30.0 + b_x - 20.0 - 80.0 = -140,$$

which gives $b_x = -70.0 \text{ cm}$.

(b) Along the y axis we have

$$40.0 - 70.0 + c_y - 70.0 = -20.0$$

which yields $c_y = 80.0 \text{ cm}$.

(c) The magnitude of the final location $(-140, -20.0)$ is $\sqrt{(-140)^2 + (-20.0)^2} = 141 \text{ cm}$.

(d) Since the displacement is in the third quadrant, the angle of the overall displacement is given by $\pi + \tan^{-1}[(-20.0)/(-140)]$ or 188° counterclockwise from the $+x$ axis (or -172° counterclockwise from the $+x$ axis).

22. Angles are given in ‘standard’ fashion, so Eq. 3-5 applies directly. We use this to write the vectors in unit-vector notation before adding them. However, a very different-looking approach using the special capabilities of most graphical calculators can be imagined. Wherever the length unit is not displayed in the solution below, the unit meter should be understood.

(a) Allowing for the different angle units used in the problem statement, we arrive at

$$\vec{E} = 3.73 \hat{i} + 4.70 \hat{j}$$

$$\vec{F} = 1.29 \hat{i} - 4.83 \hat{j}$$

$$\vec{G} = 1.45 \hat{i} + 3.73 \hat{j}$$

$$\vec{H} = -5.20 \hat{i} + 3.00 \hat{j}$$

$$\vec{E} + \vec{F} + \vec{G} + \vec{H} = 1.28 \hat{i} + 6.60 \hat{j}.$$

(b) The magnitude of the vector sum found in part (a) is $\sqrt{(1.28 \text{ m})^2 + (6.60 \text{ m})^2} = 6.72 \text{ m}$.

(c) Its angle measured counterclockwise from the $+x$ axis is $\tan^{-1}(6.60/1.28) = 79.0^\circ$.

(d) Using the conversion factor $\pi \text{ rad} = 180^\circ$, $79.0^\circ = 1.38 \text{ rad}$.

23. The resultant (along the y axis, with the same magnitude as \vec{C}) forms (along with \vec{C}) a side of an isosceles triangle (with \vec{B} forming the base). If the angle between \vec{C} and the y axis is $\theta = \tan^{-1}(3/4) = 36.87^\circ$, then it should be clear that (referring to the magnitudes of the vectors) $B = 2C \sin(\theta/2)$. Thus (since $C = 5.0$) we find $B = 3.2$.

24. As a vector addition problem, we express the situation (described in the problem statement) as $\vec{A} + \vec{B} = (3A)\hat{j}$, where $\vec{A} = A\hat{i}$ and $B = 7.0 \text{ m}$. Since $\hat{i} \perp \hat{j}$ we may use the Pythagorean theorem to express B in terms of the magnitudes of the other two vectors:

$$B = \sqrt{(3A)^2 + A^2} \quad \Rightarrow \quad A = \frac{1}{\sqrt{10}} B = 2.2 \text{ m}.$$

25. The strategy is to find where the camel is (\vec{C}) by adding the two consecutive displacements described in the problem, and then finding the difference between that location and the oasis (\vec{B}). Using the magnitude-angle notation

$$\vec{C} = (24 \angle -15^\circ) + (8.0 \angle 90^\circ) = (23.25 \angle 4.41^\circ)$$

so

$$\vec{B} - \vec{C} = (25 \angle 0^\circ) - (23.25 \angle 4.41^\circ) = (2.5 \angle -45^\circ)$$

which is efficiently implemented using a vector-capable calculator in polar mode. The distance is therefore 2.6 km.

26. The vector equation is $\vec{R} = \vec{A} + \vec{B} + \vec{C} + \vec{D}$. Expressing \vec{B} and \vec{D} in unit-vector notation, we have $(1.69\hat{i} + 3.63\hat{j}) \text{ m}$ and $(-2.87\hat{i} + 4.10\hat{j}) \text{ m}$, respectively. Where the length unit is not displayed in the solution below, the unit meter should be understood.

(a) Adding corresponding components, we obtain $\vec{R} = (-3.18 \text{ m})\hat{i} + (4.72 \text{ m})\hat{j}$.

(b) Using Eq. 3-6, the magnitude is

$$|\vec{R}| = \sqrt{(-3.18 \text{ m})^2 + (4.72 \text{ m})^2} = 5.69 \text{ m}.$$

(c) The angle is

$$\theta = \tan^{-1}\left(\frac{4.72 \text{ m}}{-3.18 \text{ m}}\right) = -56.0^\circ \text{ (with } -x \text{ axis)}.$$

If measured counterclockwise from $+x$ -axis, the angle is then $180^\circ - 56.0^\circ = 124^\circ$. Thus, converting the result to polar coordinates, we obtain

$$(-3.18, 4.72) \rightarrow (5.69 \angle 124^\circ)$$

27. Solving the simultaneous equations yields the answers:

(a) $\vec{d}_1 = 4\vec{d}_3 = 8\hat{i} + 16\hat{j}$, and

(b) $\vec{d}_2 = \vec{d}_3 = 2\hat{i} + 4\hat{j}$.

28. Let \vec{A} represent the first part of Beetle 1's trip (0.50 m east or $0.5\hat{i}$) and \vec{C} represent the first part of Beetle 2's trip intended voyage (1.6 m at 50° north of east). For their respective second parts: \vec{B} is 0.80 m at 30° north of east and \vec{D} is the unknown. The final position of Beetle 1 is

$$\vec{A} + \vec{B} = (0.5 \text{ m})\hat{i} + (0.8 \text{ m})(\cos 30^\circ \hat{i} + \sin 30^\circ \hat{j}) = (1.19 \text{ m})\hat{i} + (0.40 \text{ m})\hat{j}.$$

The equation relating these is $\vec{A} + \vec{B} = \vec{C} + \vec{D}$, where

$$\vec{C} = (1.60 \text{ m})(\cos 50.0^\circ \hat{i} + \sin 50.0^\circ \hat{j}) = (1.03 \text{ m})\hat{i} + (1.23 \text{ m})\hat{j}$$

(a) We find $\vec{D} = \vec{A} + \vec{B} - \vec{C} = (0.16 \text{ m})\hat{i} + (-0.83 \text{ m})\hat{j}$, and the magnitude is $D = 0.84 \text{ m}$.

(b) The angle is $\tan^{-1}(-0.83/0.16) = -79^\circ$, which is interpreted to mean 79° south of east (or 11° east of south).

29. Let $l_0 = 2.0 \text{ cm}$ be the length of each segment. The nest is located at the endpoint of segment w .

(a) Using unit-vector notation, the displacement vector for point A is

$$\begin{aligned} \vec{d}_A &= \vec{w} + \vec{v} + \vec{i} + \vec{h} = l_0(\cos 60^\circ \hat{i} + \sin 60^\circ \hat{j}) + (l_0 \hat{j}) + l_0(\cos 120^\circ \hat{i} + \sin 120^\circ \hat{j}) + (l_0 \hat{j}) \\ &= (2 + \sqrt{3})l_0 \hat{j}. \end{aligned}$$

Therefore, the magnitude of \vec{d}_A is $|\vec{d}_A| = (2 + \sqrt{3})(2.0 \text{ cm}) = 7.5 \text{ cm}$.

(b) The angle of \vec{d}_A is $\theta = \tan^{-1}(d_{A,y}/d_{A,x}) = \tan^{-1}(\infty) = 90^\circ$.

(c) Similarly, the displacement for point B is

$$\begin{aligned}
 \vec{d}_B &= \vec{w} + \vec{v} + \vec{j} + \vec{p} + \vec{o} \\
 &= l_0(\cos 60^\circ \hat{i} + \sin 60^\circ \hat{j}) + (l_0 \hat{j}) + l_0(\cos 60^\circ \hat{i} + \sin 60^\circ \hat{j}) + l_0(\cos 30^\circ \hat{i} + \sin 30^\circ \hat{j}) + (l_0 \hat{i}) \\
 &= (2 + \sqrt{3}/2)l_0 \hat{i} + (3/2 + \sqrt{3})l_0 \hat{j}.
 \end{aligned}$$

Therefore, the magnitude of \vec{d}_B is

$$|\vec{d}_B| = l_0 \sqrt{(2 + \sqrt{3}/2)^2 + (3/2 + \sqrt{3})^2} = (2.0 \text{ cm})(4.3) = 8.6 \text{ cm}.$$

(d) The direction of \vec{d}_B is

$$\theta_B = \tan^{-1} \left(\frac{d_{B,y}}{d_{B,x}} \right) = \tan^{-1} \left(\frac{3/2 + \sqrt{3}}{2 + \sqrt{3}/2} \right) = \tan^{-1}(1.13) = 48^\circ.$$

30. Many of the operations are done efficiently on most modern graphical calculators using their built-in vector manipulation and rectangular \leftrightarrow polar “shortcuts.” In this solution, we employ the “traditional” methods (such as Eq. 3-6).

(a) The magnitude of \vec{a} is $a = \sqrt{(4.0 \text{ m})^2 + (-3.0 \text{ m})^2} = 5.0 \text{ m}$.

(b) The angle between \vec{a} and the $+x$ axis is $\tan^{-1} [(-3.0 \text{ m})/(4.0 \text{ m})] = -37^\circ$. The vector is 37° clockwise from the axis defined by \hat{i} .

(c) The magnitude of \vec{b} is $b = \sqrt{(6.0 \text{ m})^2 + (8.0 \text{ m})^2} = 10 \text{ m}$.

(d) The angle between \vec{b} and the $+x$ axis is $\tan^{-1} [(8.0 \text{ m})/(6.0 \text{ m})] = 53^\circ$.

(e) $\vec{a} + \vec{b} = (4.0 \text{ m} + 6.0 \text{ m}) \hat{i} + [(-3.0 \text{ m}) + 8.0 \text{ m}] \hat{j} = (10 \text{ m}) \hat{i} + (5.0 \text{ m}) \hat{j}$. The magnitude of this vector is $|\vec{a} + \vec{b}| = \sqrt{(10 \text{ m})^2 + (5.0 \text{ m})^2} = 11 \text{ m}$; we round to two significant figures in our results.

(f) The angle between the vector described in part (e) and the $+x$ axis is $\tan^{-1} [(5.0 \text{ m})/(10 \text{ m})] = 27^\circ$.

(g) $\vec{b} - \vec{a} = (6.0 \text{ m} - 4.0 \text{ m}) \hat{i} + [8.0 \text{ m} - (-3.0 \text{ m})] \hat{j} = (2.0 \text{ m}) \hat{i} + (11 \text{ m}) \hat{j}$. The magnitude of this vector is $|\vec{b} - \vec{a}| = \sqrt{(2.0 \text{ m})^2 + (11 \text{ m})^2} = 11 \text{ m}$, which is, interestingly, the same result as in part (e) (exactly, not just to 2 significant figures) (this curious coincidence is made possible by the fact that $\vec{a} \perp \vec{b}$).

(h) The angle between the vector described in part (g) and the $+x$ axis is $\tan^{-1}[(11 \text{ m})/(2.0 \text{ m})] = 80^\circ$.

(i) $\vec{a} - \vec{b} = (4.0 \text{ m} - 6.0 \text{ m}) \hat{i} + [(-3.0 \text{ m}) - 8.0 \text{ m}] \hat{j} = (-2.0 \text{ m}) \hat{i} + (-11 \text{ m}) \hat{j}$. The magnitude of this vector is

$$|\vec{a} - \vec{b}| = \sqrt{(-2.0 \text{ m})^2 + (-11 \text{ m})^2} = 11 \text{ m}.$$

(j) The two possibilities presented by a simple calculation for the angle between the vector described in part (i) and the $+x$ direction are $\tan^{-1}[(-11 \text{ m})/(-2.0 \text{ m})] = 80^\circ$, and $180^\circ + 80^\circ = 260^\circ$. The latter possibility is the correct answer (see part (k) for a further observation related to this result).

(k) Since $\vec{a} - \vec{b} = (-1)(\vec{b} - \vec{a})$, they point in opposite (anti-parallel) directions; the angle between them is 180° .

31. (a) With $a = 17.0 \text{ m}$ and $\theta = 56.0^\circ$ we find $a_x = a \cos \theta = 9.51 \text{ m}$.

(b) Similarly, $a_y = a \sin \theta = 14.1 \text{ m}$.

(c) The angle relative to the new coordinate system is $\theta' = (56.0^\circ - 18.0^\circ) = 38.0^\circ$. Thus, $a'_x = a \cos \theta' = 13.4 \text{ m}$.

(d) Similarly, $a'_y = a \sin \theta' = 10.5 \text{ m}$.

32. (a) As can be seen from Figure 3-30, the point diametrically opposite the origin $(0,0,0)$ has position vector $a \hat{i} + a \hat{j} + a \hat{k}$ and this is the vector along the “body diagonal.”

(b) From the point $(a, 0, 0)$, which corresponds to the position vector $a \hat{i}$, the diametrically opposite point is $(0, a, a)$ with the position vector $a \hat{j} + a \hat{k}$. Thus, the vector along the line is the difference $-a \hat{i} + a \hat{j} + a \hat{k}$.

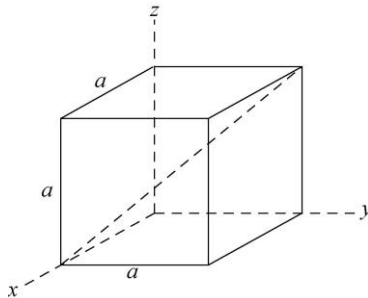

(c) If the starting point is $(0, a, 0)$ with the corresponding position vector $a \hat{j}$, the diametrically opposite point is $(a, 0, a)$ with the position vector $a \hat{i} + a \hat{k}$. Thus, the vector along the line is the difference $a \hat{i} - a \hat{j} + a \hat{k}$.

(d) If the starting point is $(a, a, 0)$ with the corresponding position vector $a \hat{i} + a \hat{j}$, the diametrically opposite point is $(0, 0, a)$ with the position vector $a \hat{k}$. Thus, the vector along the line is the difference $-a \hat{i} - a \hat{j} + a \hat{k}$.

(e) Consider the vector from the back lower left corner to the front upper right corner. It is $a \hat{i} + a \hat{j} + a \hat{k}$. We may think of it as the sum of the vector $a \hat{i}$ parallel to the x axis and the vector $a \hat{j} + a \hat{k}$ perpendicular to the x axis. The tangent of the angle between the vector and the x axis is the perpendicular component divided by the parallel component. Since the magnitude of the perpendicular component is $\sqrt{a^2 + a^2} = a\sqrt{2}$ and the magnitude of the parallel component is a , $\tan \theta = (a\sqrt{2})/a = \sqrt{2}$. Thus $\theta = 54.7^\circ$. The angle between the vector and each of the other two adjacent sides (the y and z axes) is the same as is the angle between any of the other diagonal vectors and any of the cube sides adjacent to them.

(f) The length of any of the diagonals is given by $\sqrt{a^2 + a^2 + a^2} = a\sqrt{3}$.

33. Examining the figure, we see that $\vec{a} + \vec{b} + \vec{c} = 0$, where $\vec{a} \perp \vec{b}$.

(a) $|\vec{a} \times \vec{b}| = (3.0)(4.0) = 12$ since the angle between them is 90° .

(b) Using the Right-Hand Rule, the vector $\vec{a} \times \vec{b}$ points in the $\hat{i} \times \hat{j} = \hat{k}$, or the $+z$ direction.

(c) $|\vec{a} \times \vec{c}| = |\vec{a} \times (-\vec{a} - \vec{b})| = |-(\vec{a} \times \vec{b})| = 12$.

(d) The vector $-\vec{a} \times \vec{b}$ points in the $-\hat{i} \times \hat{j} = -\hat{k}$, or the $-z$ direction.

(e) $|\vec{b} \times \vec{c}| = |\vec{b} \times (-\vec{a} - \vec{b})| = |-(\vec{b} \times \vec{a})| = |(\vec{a} \times \vec{b})| = 12$.

(f) The vector points in the $+z$ direction, as in part (a).

34. We apply Eq. 3-23 and Eq. 3-27.

(a) $\vec{a} \times \vec{b} = (a_x b_y - a_y b_x) \hat{k}$ since all other terms vanish, due to the fact that neither \vec{a} nor \vec{b} have any z components. Consequently, we obtain $[(3.0)(4.0) - (5.0)(2.0)]\hat{k} = 2.0\hat{k}$.

(b) $\vec{a} \cdot \vec{b} = a_x b_x + a_y b_y$ yields $(3.0)(2.0) + (5.0)(4.0) = 26$.

(c) $\vec{a} + \vec{b} = (3.0 + 2.0)\hat{i} + (5.0 + 4.0)\hat{j} \Rightarrow (\vec{a} + \vec{b}) \cdot \vec{b} = (5.0)(2.0) + (9.0)(4.0) = 46$.

(d) Several approaches are available. In this solution, we will construct a \hat{b} unit-vector and “dot” it (take the scalar product of it) with \vec{a} . In this case, we make the desired unit-vector by

$$\hat{b} = \frac{\vec{b}}{|\vec{b}|} = \frac{2.0 \hat{i} + 4.0 \hat{j}}{\sqrt{(2.0)^2 + (4.0)^2}}.$$

We therefore obtain

$$a_b = \vec{a} \cdot \hat{b} = \frac{(3.0)(2.0) + (5.0)(4.0)}{\sqrt{(2.0)^2 + (4.0)^2}} = 5.8.$$

35. (a) The scalar or dot product is $(4.50)(7.30)\cos(320^\circ - 85.0^\circ) = -18.8$.

(b) The vector or cross product is in the \hat{k} direction (by the right-hand rule) with magnitude $|(4.50)(7.30) \sin(320^\circ - 85.0^\circ)| = 26.9$.

36. First, we rewrite the given expression as $4(\vec{d}_{\text{plane}} \cdot \vec{d}_{\text{cross}})$ where $\vec{d}_{\text{plane}} = \vec{d}_1 + \vec{d}_2$ and in the plane of \vec{d}_1 and \vec{d}_2 , and $\vec{d}_{\text{cross}} = \vec{d}_1 \times \vec{d}_2$. Noting that \vec{d}_{cross} is perpendicular to the plane of \vec{d}_1 and \vec{d}_2 , we see that the answer must be 0 (the scalar or dot product of perpendicular vectors is zero).

37. We apply Eq. 3-23 and Eq.3-27. If a vector-capable calculator is used, this makes a good exercise for getting familiar with those features. Here we briefly sketch the method.

(a) We note that $\vec{b} \times \vec{c} = -8.0\hat{i} + 5.0\hat{j} + 6.0\hat{k}$. Thus,

$$\vec{a} \cdot (\vec{b} \times \vec{c}) = (3.0)(-8.0) + (3.0)(5.0) + (-2.0)(6.0) = -21.$$

(b) We note that $\vec{b} + \vec{c} = 1.0\hat{i} - 2.0\hat{j} + 3.0\hat{k}$. Thus,

$$\vec{a} \cdot (\vec{b} + \vec{c}) = (3.0)(1.0) + (3.0)(-2.0) + (-2.0)(3.0) = -9.0.$$

(c) Finally,

$$\begin{aligned} \vec{a} \times (\vec{b} + \vec{c}) &= [(3.0)(3.0) - (-2.0)(-2.0)] \hat{i} + [(-2.0)(1.0) - (3.0)(3.0)] \hat{j} \\ &\quad + [(3.0)(-2.0) - (3.0)(1.0)] \hat{k} \\ &= 5\hat{i} - 11\hat{j} - 9\hat{k} \end{aligned}$$

38. Using the fact that

$$\hat{i} \times \hat{j} = \hat{k}, \quad \hat{j} \times \hat{k} = \hat{i}, \quad \hat{k} \times \hat{i} = \hat{j}$$

we obtain

$$\begin{aligned} 2\vec{A} \times \vec{B} &= 2(2.00\hat{i} + 3.00\hat{j} - 4.00\hat{k}) \times (-3.00\hat{i} + 4.00\hat{j} + 2.00\hat{k}) \\ &= 44.0\hat{i} + 16.0\hat{j} + 34.0\hat{k}. \end{aligned}$$

Next, making use of

$$\begin{aligned} \hat{i} \cdot \hat{i} = \hat{j} \cdot \hat{j} = \hat{k} \cdot \hat{k} &= 1 \\ \hat{i} \cdot \hat{j} = \hat{j} \cdot \hat{k} = \hat{k} \cdot \hat{i} &= 0 \end{aligned}$$

we have

$$\begin{aligned} 3\vec{C} \cdot (2\vec{A} \times \vec{B}) &= 3(7.00\hat{i} - 8.00\hat{j}) \cdot (44.0\hat{i} + 16.0\hat{j} + 34.0\hat{k}) \\ &= 3[(7.00)(44.0) + (-8.00)(16.0) + (0)(34.0)] = 540. \end{aligned}$$

39. From the definition of the dot product between \vec{A} and \vec{B} , $\vec{A} \cdot \vec{B} = AB \cos \theta$, we have

$$\cos \theta = \frac{\vec{A} \cdot \vec{B}}{AB}$$

With $A = 6.00$, $B = 7.00$ and $\vec{A} \cdot \vec{B} = 14.0$, $\cos \theta = 0.333$, or $\theta = 70.5^\circ$.

40. The displacement vectors can be written as (in meters)

$$\begin{aligned} \vec{d}_1 &= (4.50 \text{ m})(\cos 63^\circ \hat{j} + \sin 63^\circ \hat{k}) = (2.04 \text{ m})\hat{j} + (4.01 \text{ m})\hat{k} \\ \vec{d}_2 &= (1.40 \text{ m})(\cos 30^\circ \hat{i} + \sin 30^\circ \hat{k}) = (1.21 \text{ m})\hat{i} + (0.70 \text{ m})\hat{k}. \end{aligned}$$

(a) The dot product of \vec{d}_1 and \vec{d}_2 is

$$\vec{d}_1 \cdot \vec{d}_2 = (2.04\hat{j} + 4.01\hat{k}) \cdot (1.21\hat{i} + 0.70\hat{k}) = (4.01\hat{k}) \cdot (0.70\hat{k}) = 2.81 \text{ m}^2.$$

(b) The cross product of \vec{d}_1 and \vec{d}_2 is

$$\begin{aligned} \vec{d}_1 \times \vec{d}_2 &= (2.04\hat{j} + 4.01\hat{k}) \times (1.21\hat{i} + 0.70\hat{k}) \\ &= (2.04)(1.21)(-\hat{k}) + (2.04)(0.70)\hat{i} + (4.01)(1.21)\hat{j} \\ &= (1.43\hat{i} + 4.86\hat{j} - 2.48\hat{k}) \text{ m}^2. \end{aligned}$$

(c) The magnitudes of \vec{d}_1 and \vec{d}_2 are

$$\begin{aligned} d_1 &= \sqrt{(2.04 \text{ m})^2 + (4.01 \text{ m})^2} = 4.50 \text{ m} \\ d_2 &= \sqrt{(1.21 \text{ m})^2 + (0.70 \text{ m})^2} = 1.40 \text{ m}. \end{aligned}$$

Thus, the angle between the two vectors is

$$\theta = \cos^{-1} \left(\frac{\vec{d}_1 \cdot \vec{d}_2}{d_1 d_2} \right) = \cos^{-1} \left(\frac{2.81 \text{ m}^2}{(4.50 \text{ m})(1.40 \text{ m})} \right) = 63.5^\circ.$$

41. **THINK** The angle between two vectors can be calculated using the definition of scalar product.

EXPRESS Since the scalar product of two vectors \vec{a} and \vec{b} is

$$\vec{a} \cdot \vec{b} = ab \cos \phi = a_x b_x + a_y b_y + a_z b_z,$$

the angle between them is given by

$$\cos \phi = \frac{a_x b_x + a_y b_y + a_z b_z}{ab} \Rightarrow \phi = \cos^{-1} \left(\frac{a_x b_x + a_y b_y + a_z b_z}{ab} \right).$$

Once the magnitudes and components of the vectors are known, the angle ϕ can be readily calculated.

ANALYZE Given that $\vec{a} = (3.0)\hat{i} + (3.0)\hat{j} + (3.0)\hat{k}$ and $\vec{b} = (2.0)\hat{i} + (1.0)\hat{j} + (3.0)\hat{k}$, the magnitudes of the vectors are

$$a = |\vec{a}| = \sqrt{a_x^2 + a_y^2 + a_z^2} = \sqrt{(3.0)^2 + (3.0)^2 + (3.0)^2} = 5.20$$

$$b = |\vec{b}| = \sqrt{b_x^2 + b_y^2 + b_z^2} = \sqrt{(2.0)^2 + (1.0)^2 + (3.0)^2} = 3.74.$$

The angle between them is found to be

$$\cos \phi = \frac{(3.0)(2.0) + (3.0)(1.0) + (3.0)(3.0)}{(5.20)(3.74)} = 0.926,$$

or $\phi = 22^\circ$.

LEARN As the name implies, the scalar product (or dot product) between two vectors is a scalar quantity. It can be regarded as the product between the magnitude of one of the vectors and the scalar component of the second vector along the direction of the first one, as illustrated below (see also in Fig. 3-18 of the text):

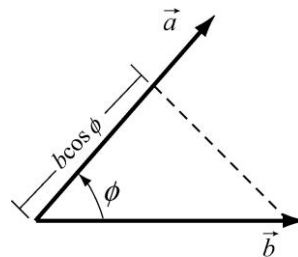

$$\vec{a} \cdot \vec{b} = ab \cos \phi = (a)(b \cos \phi)$$

42. The two vectors are written as, in unit of meters,

$$\vec{d}_1 = 4.0\hat{i} + 5.0\hat{j} = d_{1x}\hat{i} + d_{1y}\hat{j}, \quad \vec{d}_2 = -3.0\hat{i} + 4.0\hat{j} = d_{2x}\hat{i} + d_{2y}\hat{j}$$

(a) The vector (cross) product gives

$$\vec{d}_1 \times \vec{d}_2 = (d_{1x}d_{2y} - d_{1y}d_{2x})\hat{k} = [(4.0)(4.0) - (5.0)(-3.0)]\hat{k} = 31\hat{k}$$

(b) The scalar (dot) product gives

$$\vec{d}_1 \cdot \vec{d}_2 = d_{1x}d_{2x} + d_{1y}d_{2y} = (4.0)(-3.0) + (5.0)(4.0) = 8.0.$$

(c)

$$(\vec{d}_1 + \vec{d}_2) \cdot \vec{d}_2 = \vec{d}_1 \cdot \vec{d}_2 + d_2^2 = 8.0 + (-3.0)^2 + (4.0)^2 = 33.$$

(d) Note that the magnitude of the d_1 vector is $\sqrt{16+25} = 6.4$. Now, the dot product is $(6.4)(5.0)\cos\theta = 8$. Dividing both sides by 32 and taking the inverse cosine yields $\theta = 75.5^\circ$. Therefore the component of the d_1 vector along the direction of the d_2 vector is $6.4\cos\theta \approx 1.6$.

43. **THINK** In this problem we are given three vectors \vec{a} , \vec{b} and \vec{c} on the xy -plane, and asked to calculate their components.

EXPRESS From the figure, we note that $\vec{c} \perp \vec{b}$, which implies that the angle between \vec{c} and the $+x$ axis is $\theta + 90^\circ$. In unit-vector notation, the three vectors can be written as

$$\begin{aligned} \vec{a} &= a_x\hat{i} \\ \vec{b} &= b_x\hat{i} + b_y\hat{j} = (b\cos\theta)\hat{i} + (b\sin\theta)\hat{j} \\ \vec{c} &= c_x\hat{i} + c_y\hat{j} = [c\cos(\theta + 90^\circ)]\hat{i} + [c\sin(\theta + 90^\circ)]\hat{j}. \end{aligned}$$

The above expressions allow us to evaluate the components of the vectors.

ANALYZE (a) The x -component of \vec{a} is $a_x = a\cos 0^\circ = a = 3.00$ m.

(b) Similarly, the y -component of \vec{a} is $a_y = a\sin 0^\circ = 0$.

(c) The x -component of \vec{b} is $b_x = b\cos 30^\circ = (4.00 \text{ m})\cos 30^\circ = 3.46$ m,

(d) and the y -component is $b_y = b\sin 30^\circ = (4.00 \text{ m})\sin 30^\circ = 2.00$ m.

(e) The x -component of \vec{c} is $c_x = c\cos 120^\circ = (10.0 \text{ m})\cos 120^\circ = -5.00$ m,

(f) and the y -component is $c_y = c \sin 30^\circ = (10.0 \text{ m}) \sin 120^\circ = 8.66 \text{ m}$.

(g) The fact that $\vec{c} = p\vec{a} + q\vec{b}$ implies

$$\vec{c} = c_x \hat{i} + c_y \hat{j} = p(a_x \hat{i}) + q(b_x \hat{i} + b_y \hat{j}) = (pa_x + qb_x) \hat{i} + qb_y \hat{j}$$

or

$$c_x = pa_x + qb_x, \quad c_y = qb_y.$$

Substituting the values found above, we have

$$\begin{aligned} -5.00 \text{ m} &= p(3.00 \text{ m}) + q(3.46 \text{ m}) \\ 8.66 \text{ m} &= q(2.00 \text{ m}). \end{aligned}$$

Solving these equations, we find $p = -6.67$.

(h) Similarly, $q = 4.33$ (note that it's easiest to solve for q first). The numbers p and q have no units.

LEARN This exercise shows that given two (non-parallel) vectors in two dimensions, the third vector can always be written as a linear combination of the first two.

44. Applying Eq. 3-23, $\vec{F} = q\vec{v} \times \vec{B}$ (where q is a scalar) becomes

$$F_x \hat{i} + F_y \hat{j} + F_z \hat{k} = q(v_y B_z - v_z B_y) \hat{i} + q(v_z B_x - v_x B_z) \hat{j} + q(v_x B_y - v_y B_x) \hat{k}$$

which — plugging in values — leads to three equalities:

$$\begin{aligned} 4.0 &= 2(4.0B_z - 6.0B_y) \\ -20 &= 2(6.0B_x - 2.0B_z) \\ 12 &= 2(2.0B_y - 4.0B_x) \end{aligned}$$

Since we are told that $B_x = B_y$, the third equation leads to $B_y = -3.0$. Inserting this value into the first equation, we find $B_z = -4.0$. Thus, our answer is

$$\vec{B} = -3.0 \hat{i} - 3.0 \hat{j} - 4.0 \hat{k}.$$

45. The two vectors are given by

$$\begin{aligned} \vec{A} &= 8.00(\cos 130^\circ \hat{i} + \sin 130^\circ \hat{j}) = -5.14 \hat{i} + 6.13 \hat{j} \\ \vec{B} &= B_x \hat{i} + B_y \hat{j} = -7.72 \hat{i} - 9.20 \hat{j}. \end{aligned}$$

(a) The dot product of $5\vec{A} \cdot \vec{B}$ is

$$5\vec{A} \cdot \vec{B} = 5(-5.14\hat{i} + 6.13\hat{j}) \cdot (-7.72\hat{i} - 9.20\hat{j}) = 5[(-5.14)(-7.72) + (6.13)(-9.20)] \\ = -83.4.$$

(b) In unit vector notation

$$4\vec{A} \times 3\vec{B} = 12\vec{A} \times \vec{B} = 12(-5.14\hat{i} + 6.13\hat{j}) \times (-7.72\hat{i} - 9.20\hat{j}) = 12(94.6\hat{k}) = 1.14 \times 10^3 \hat{k}$$

(c) We note that the azimuthal angle is undefined for a vector along the z axis. Thus, our result is “ 1.14×10^3 , θ not defined, and $\phi = 0^\circ$.”

(d) Since \vec{A} is in the xy plane, and $\vec{A} \times \vec{B}$ is perpendicular to that plane, then the answer is 90° .

(e) Clearly, $\vec{A} + 3.00\hat{k} = -5.14\hat{i} + 6.13\hat{j} + 3.00\hat{k}$.

(f) The Pythagorean theorem yields magnitude $A = \sqrt{(5.14)^2 + (6.13)^2 + (3.00)^2} = 8.54$.

The azimuthal angle is $\theta = 130^\circ$, just as it was in the problem statement (\vec{A} is the projection onto the xy plane of the new vector created in part (e)). The angle measured from the $+z$ axis is

$$\phi = \cos^{-1}(3.00/8.54) = 69.4^\circ.$$

46. The vectors are shown on the diagram. The x axis runs from west to east and the y axis runs from south to north. Then $a_x = 5.0$ m, $a_y = 0$,

$$b_x = -(4.0 \text{ m}) \sin 35^\circ = -2.29 \text{ m}, \quad b_y = (4.0 \text{ m}) \cos 35^\circ = 3.28 \text{ m}.$$

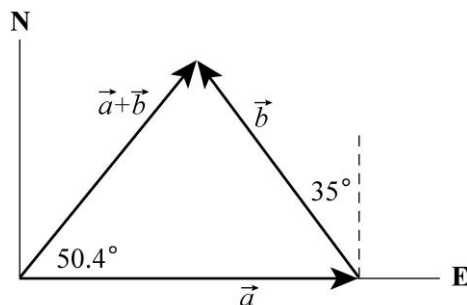

(a) Let $\vec{c} = \vec{a} + \vec{b}$. Then $c_x = a_x + b_x = 5.00 \text{ m} - 2.29 \text{ m} = 2.71 \text{ m}$ and $c_y = a_y + b_y = 0 + 3.28 \text{ m} = 3.28 \text{ m}$. The magnitude of c is

$$c = \sqrt{c_x^2 + c_y^2} = \sqrt{(2.71\text{m})^2 + (3.28\text{m})^2} = 4.2 \text{ m}.$$

(b) The angle θ that $\vec{c} = \vec{a} + \vec{b}$ makes with the $+x$ axis is

$$\theta = \tan^{-1}\left(\frac{c_y}{c_x}\right) = \tan^{-1}\left(\frac{3.28}{2.71}\right) = 50.5^\circ \approx 50^\circ.$$

The second possibility ($\theta = 50.4^\circ + 180^\circ = 230.4^\circ$) is rejected because it would point in a direction opposite to \vec{c} .

(c) The vector $\vec{b} - \vec{a}$ is found by adding $-\vec{a}$ to \vec{b} . The result is shown on the diagram to the right. Let $\vec{c} = \vec{b} - \vec{a}$. The components are

$$\begin{aligned} c_x &= b_x - a_x = -2.29 \text{ m} - 5.00 \text{ m} = -7.29 \text{ m} \\ c_y &= b_y - a_y = 3.28 \text{ m}. \end{aligned}$$

The magnitude of \vec{c} is $c = \sqrt{c_x^2 + c_y^2} = 8.0 \text{ m}$.

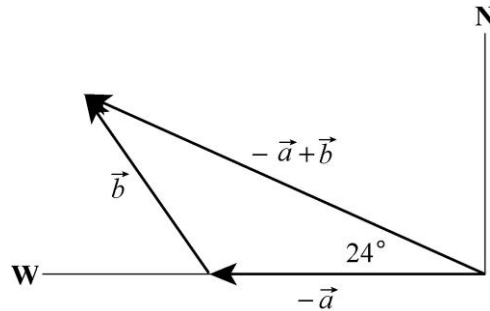

(d) The tangent of the angle θ that \vec{c} makes with the $+x$ axis (east) is

$$\tan \theta = \frac{c_y}{c_x} = \frac{3.28 \text{ m}}{-7.29 \text{ m}} = -4.50.$$

There are two solutions: -24.2° and 155.8° . As the diagram shows, the second solution is correct. The vector $\vec{c} = -\vec{a} + \vec{b}$ is 24° north of west.

47. Noting that the given 130° is measured counterclockwise from the $+x$ axis, the two vectors can be written as

$$\begin{aligned} \vec{A} &= 8.00(\cos 130^\circ \hat{i} + \sin 130^\circ \hat{j}) = -5.14 \hat{i} + 6.13 \hat{j} \\ \vec{B} &= B_x \hat{i} + B_y \hat{j} = -7.72 \hat{i} - 9.20 \hat{j}. \end{aligned}$$

(a) The angle between the negative direction of the y axis ($-\hat{j}$) and the direction of \vec{A} is

$$\theta = \cos^{-1} \left(\frac{\vec{A} \cdot (-\hat{j})}{A} \right) = \cos^{-1} \left(\frac{-6.13}{\sqrt{(-5.14)^2 + (6.13)^2}} \right) = \cos^{-1} \left(\frac{-6.13}{8.00} \right) = 140^\circ.$$

Alternatively, one may say that the $-y$ direction corresponds to an angle of 270° , and the answer is simply given by $270^\circ - 130^\circ = 140^\circ$.

(b) Since the y axis is in the xy plane, and $\vec{A} \times \vec{B}$ is perpendicular to that plane, then the answer is 90.0° .

(c) The vector can be simplified as

$$\begin{aligned} \vec{A} \times (\vec{B} + 3.00\hat{k}) &= (-5.14\hat{i} + 6.13\hat{j}) \times (-7.72\hat{i} - 9.20\hat{j} + 3.00\hat{k}) \\ &= 18.39\hat{i} + 15.42\hat{j} + 94.61\hat{k} \end{aligned}$$

Its magnitude is $|\vec{A} \times (\vec{B} + 3.00\hat{k})| = 97.6$. The angle between the negative direction of the y axis ($-\hat{j}$) and the direction of the above vector is

$$\theta = \cos^{-1} \left(\frac{-15.42}{97.6} \right) = 99.1^\circ.$$

48. Where the length unit is not displayed, the unit meter is understood.

(a) We first note that the magnitudes of the vectors are $a = |\vec{a}| = \sqrt{(3.2)^2 + (1.6)^2} = 3.58$ and $b = |\vec{b}| = \sqrt{(0.50)^2 + (4.5)^2} = 4.53$. Now,

$$\begin{aligned} \vec{a} \cdot \vec{b} &= a_x b_x + a_y b_y = ab \cos \phi \\ (3.2)(0.50) + (1.6)(4.5) &= (3.58)(4.53) \cos \phi \end{aligned}$$

which leads to $\phi = 57^\circ$ (the inverse cosine is double-valued as is the inverse tangent, but we know this is the right solution since both vectors are in the same quadrant).

(b) Since the angle (measured from $+x$) for \vec{a} is $\tan^{-1}(1.6/3.2) = 26.6^\circ$, we know the angle for \vec{c} is $26.6^\circ - 90^\circ = -63.4^\circ$ (the other possibility, $26.6^\circ + 90^\circ$ would lead to a $c_x < 0$). Therefore,

$$c_x = c \cos(-63.4^\circ) = (5.0)(0.45) = 2.2 \text{ m.}$$

(c) Also, $c_y = c \sin(-63.4^\circ) = (5.0)(-0.89) = -4.5 \text{ m.}$

(d) And we know the angle for \vec{d} to be $26.6^\circ + 90^\circ = 116.6^\circ$, which leads to

$$d_x = d \cos(116.6^\circ) = (5.0)(-0.45) = -2.2 \text{ m.}$$

(e) Finally, $d_y = d \sin 116.6^\circ = (5.0)(0.89) = 4.5 \text{ m.}$

49. **THINK** This problem deals with the displacement of a sailboat. We want to find the displacement vector between two locations.

EXPRESS The situation is depicted in the figure below. Let \vec{a} represent the first part of his actual voyage (50.0 km east) and \vec{c} represent the intended voyage (90.0 km north). We look for a vector \vec{b} such that $\vec{c} = \vec{a} + \vec{b}$.

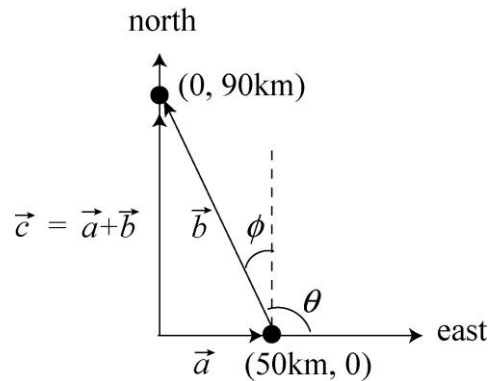

ANALYZE (a) Using the Pythagorean theorem, the distance traveled by the sailboat is

$$b = \sqrt{(50.0 \text{ km})^2 + (90.0 \text{ km})^2} = 103 \text{ km.}$$

(b) The direction is

$$\phi = \tan^{-1}\left(\frac{50.0 \text{ km}}{90.0 \text{ km}}\right) = 29.1^\circ$$

west of north (which is equivalent to 60.9° north of due west).

LEARN This problem could also be solved by first expressing the vectors in unit-vector notation: $\vec{a} = (50.0 \text{ km})\hat{i}$, $\vec{c} = (90.0 \text{ km})\hat{j}$. This gives

$$\vec{b} = \vec{c} - \vec{a} = -(50.0 \text{ km})\hat{i} + (90.0 \text{ km})\hat{j}.$$

The angle between \vec{b} and the $+x$ -axis is

$$\theta = \tan^{-1}\left(\frac{90.0 \text{ km}}{-50.0 \text{ km}}\right) = 119.1^\circ.$$

The angle θ is related to ϕ by $\theta = 90^\circ + \phi$.

50. The two vectors \vec{d}_1 and \vec{d}_2 are given by $\vec{d}_1 = -d_1 \hat{j}$ and $\vec{d}_2 = d_2 \hat{i}$.

(a) The vector $\vec{d}_2 / 4 = (d_2 / 4) \hat{i}$ points in the $+x$ direction. The $1/4$ factor does not affect the result.

(b) The vector $\vec{d}_1 / (-4) = (d_1 / 4) \hat{j}$ points in the $+y$ direction. The minus sign (with the “ -4 ”) does affect the direction: $-(-y) = +y$.

(c) $\vec{d}_1 \cdot \vec{d}_2 = 0$ since $\hat{i} \cdot \hat{j} = 0$. The two vectors are perpendicular to each other.

(d) $\vec{d}_1 \cdot (\vec{d}_2 / 4) = (\vec{d}_1 \cdot \vec{d}_2) / 4 = 0$, as in part (c).

(e) $\vec{d}_1 \times \vec{d}_2 = -d_1 d_2 (\hat{j} \times \hat{i}) = d_1 d_2 \hat{k}$, in the $+z$ -direction.

(f) $\vec{d}_2 \times \vec{d}_1 = -d_2 d_1 (\hat{i} \times \hat{j}) = -d_1 d_2 \hat{k}$, in the $-z$ -direction.

(g) The magnitude of the vector in (e) is $d_1 d_2$.

(h) The magnitude of the vector in (f) is $d_1 d_2$.

(i) Since $d_1 \times (\vec{d}_2 / 4) = (d_1 d_2 / 4) \hat{k}$, the magnitude is $d_1 d_2 / 4$.

(j) The direction of $\vec{d}_1 \times (\vec{d}_2 / 4) = (d_1 d_2 / 4) \hat{k}$ is in the $+z$ -direction.

51. Although we think of this as a three-dimensional movement, it is rendered effectively two-dimensional by referring measurements to its well-defined plane of the fault.

(a) The magnitude of the net displacement is

$$|\vec{AB}| = \sqrt{|AD|^2 + |AC|^2} = \sqrt{(17.0 \text{ m})^2 + (22.0 \text{ m})^2} = 27.8 \text{ m}.$$

(b) The magnitude of the vertical component of \vec{AB} is $|AD| \sin 52.0^\circ = 13.4 \text{ m}$.

52. The three vectors are

$$\begin{aligned}\vec{d}_1 &= 4.0 \hat{i} + 5.0 \hat{j} - 6.0 \hat{k} \\ \vec{d}_2 &= -1.0 \hat{i} + 2.0 \hat{j} + 3.0 \hat{k} \\ \vec{d}_3 &= 4.0 \hat{i} + 3.0 \hat{j} + 2.0 \hat{k}\end{aligned}$$

(a) $\vec{r} = \vec{d}_1 - \vec{d}_2 + \vec{d}_3 = (9.0 \text{ m})\hat{i} + (6.0 \text{ m})\hat{j} + (-7.0 \text{ m})\hat{k}$.

(b) The magnitude of \vec{r} is $|\vec{r}| = \sqrt{(9.0 \text{ m})^2 + (6.0 \text{ m})^2 + (-7.0 \text{ m})^2} = 12.9 \text{ m}$. The angle between \vec{r} and the z -axis is given by

$$\cos \theta = \frac{\vec{r} \cdot \hat{k}}{|\vec{r}|} = \frac{-7.0 \text{ m}}{12.9 \text{ m}} = -0.543$$

which implies $\theta = 123^\circ$.

(c) The component of \vec{d}_1 along the direction of \vec{d}_2 is given by $d_{\parallel} = \vec{d}_1 \cdot \hat{u} = d_1 \cos \phi$ where ϕ is the angle between \vec{d}_1 and \vec{d}_2 , and \hat{u} is the unit vector in the direction of \vec{d}_2 . Using the properties of the scalar (dot) product, we have

$$d_{\parallel} = d_1 \left(\frac{\vec{d}_1 \cdot \vec{d}_2}{d_1 d_2} \right) = \frac{\vec{d}_1 \cdot \vec{d}_2}{d_2} = \frac{(4.0)(-1.0) + (5.0)(2.0) + (-6.0)(3.0)}{\sqrt{(-1.0)^2 + (2.0)^2 + (3.0)^2}} = \frac{-12}{\sqrt{14}} = -3.2 \text{ m}.$$

(d) Now we are looking for d_{\perp} such that $d_{\perp}^2 = (4.0)^2 + (5.0)^2 + (-6.0)^2 = 77 = d_{\parallel}^2 + d_{\perp}^2$. From (c), we have

$$d_{\perp} = \sqrt{77 \text{ m}^2 - (-3.2 \text{ m})^2} = 8.2 \text{ m}.$$

This gives the magnitude of the perpendicular component (and is consistent with what one would get using Eq. 3-24), but if more information (such as the direction, or a full specification in terms of unit vectors) is sought then more computation is needed.

53. **THINK** This problem involves finding scalar and vector products between two vectors \vec{a} and \vec{b} .

EXPRESS We apply Eqs. 3-20 and 3-24 to calculate the scalar and vector products between two vectors:

$$\begin{aligned} \vec{a} \cdot \vec{b} &= ab \cos \phi \\ |\vec{a} \times \vec{b}| &= ab \sin \phi. \end{aligned}$$

ANALYZE (a) Given that $a = |\vec{a}| = 10$, $b = |\vec{b}| = 6.0$ and $\phi = 60^\circ$, the scalar (dot) product of \vec{a} and \vec{b} is

$$\vec{a} \cdot \vec{b} = ab \cos \phi = (10)(6.0) \cos 60^\circ = 30.$$

(b) Similarly, the magnitude of the vector (cross) product of the two vectors is

$$|\vec{a} \times \vec{b}| = ab \sin \phi = (10)(6.0) \sin 60^\circ = 52.$$

LEARN When two vectors \vec{a} and \vec{b} are parallel ($\phi = 0$), their scalar and vector products are $\vec{a} \cdot \vec{b} = ab \cos \phi = ab$ and $|\vec{a} \times \vec{b}| = ab \sin \phi = 0$, respectively. However, when they are perpendicular ($\phi = 90^\circ$), we have $\vec{a} \cdot \vec{b} = ab \cos \phi = 0$ and $|\vec{a} \times \vec{b}| = ab \sin \phi = ab$.

54. From the figure, it is clear that $\vec{a} + \vec{b} + \vec{c} = 0$, where $\vec{a} \perp \vec{b}$.

(a) $\vec{a} \cdot \vec{b} = 0$ since the angle between them is 90° .

(b) $\vec{a} \cdot \vec{c} = \vec{a} \cdot (-\vec{a} - \vec{b}) = -|\vec{a}|^2 = -16$.

(c) Similarly, $\vec{b} \cdot \vec{c} = -9.0$.

55. We choose $+x$ east and $+y$ north and measure all angles in the “standard” way (positive ones are counterclockwise from $+x$). Thus, vector \vec{d}_1 has magnitude $d_1 = 4.00$ m (with the unit meter) and direction $\theta_1 = 225^\circ$. Also, \vec{d}_2 has magnitude $d_2 = 5.00$ m and direction $\theta_2 = 0^\circ$, and vector \vec{d}_3 has magnitude $d_3 = 6.00$ m and direction $\theta_3 = 60^\circ$.

(a) The x -component of \vec{d}_1 is $d_{1x} = d_1 \cos \theta_1 = -2.83$ m.

(b) The y -component of \vec{d}_1 is $d_{1y} = d_1 \sin \theta_1 = -2.83$ m.

(c) The x -component of \vec{d}_2 is $d_{2x} = d_2 \cos \theta_2 = 5.00$ m.

(d) The y -component of \vec{d}_2 is $d_{2y} = d_2 \sin \theta_2 = 0$.

(e) The x -component of \vec{d}_3 is $d_{3x} = d_3 \cos \theta_3 = 3.00$ m.

(f) The y -component of \vec{d}_3 is $d_{3y} = d_3 \sin \theta_3 = 5.20$ m.

(g) The sum of x -components is

$$d_x = d_{1x} + d_{2x} + d_{3x} = -2.83 \text{ m} + 5.00 \text{ m} + 3.00 \text{ m} = 5.17 \text{ m}.$$

(h) The sum of y -components is

$$d_y = d_{1y} + d_{2y} + d_{3y} = -2.83 \text{ m} + 0 + 5.20 \text{ m} = 2.37 \text{ m}.$$

(i) The magnitude of the resultant displacement is

$$d = \sqrt{d_x^2 + d_y^2} = \sqrt{(5.17 \text{ m})^2 + (2.37 \text{ m})^2} = 5.69 \text{ m}.$$

(j) And its angle is

$$\theta = \tan^{-1}(2.37/5.17) = 24.6^\circ,$$

which (recalling our coordinate choices) means it points at about 25° north of east.

(k) and (l) This new displacement (the direct line home) when vectorially added to the previous (net) displacement must give zero. Thus, the new displacement is the negative, or opposite, of the previous (net) displacement. That is, it has the same magnitude (5.69 m) but points in the opposite direction (25° south of west).

56. If we wish to use Eq. 3-5 directly, we should note that the angles for \vec{Q} , \vec{R} , and \vec{S} are 100° , 250° , and 310° , respectively, if they are measured counterclockwise from the $+x$ axis.

(a) Using unit-vector notation, with the unit meter understood, we have

$$\begin{aligned}\vec{P} &= 10.0 \cos(25.0^\circ)\hat{i} + 10.0 \sin(25.0^\circ)\hat{j} \\ \vec{Q} &= 12.0 \cos(100^\circ)\hat{i} + 12.0 \sin(100^\circ)\hat{j} \\ \vec{R} &= 8.00 \cos(250^\circ)\hat{i} + 8.00 \sin(250^\circ)\hat{j} \\ \vec{S} &= 9.00 \cos(310^\circ)\hat{i} + 9.00 \sin(310^\circ)\hat{j} \\ \vec{P} + \vec{Q} + \vec{R} + \vec{S} &= (10.0 \text{ m})\hat{i} + (1.63 \text{ m})\hat{j}\end{aligned}$$

(b) The magnitude of the vector sum is $\sqrt{(10.0 \text{ m})^2 + (1.63 \text{ m})^2} = 10.2 \text{ m}$.

(c) The angle is $\tan^{-1}(1.63 \text{ m}/10.0 \text{ m}) \approx 9.24^\circ$ measured counterclockwise from the $+x$ axis.

57. **THINK** This problem deals with addition and subtraction of two vectors.

EXPRESS From the problem statement, we have

$$\vec{A} + \vec{B} = (6.0)\hat{i} + (1.0)\hat{j}, \quad \vec{A} - \vec{B} = -(4.0)\hat{i} + (7.0)\hat{j}$$

Solving the simultaneous equations gives \vec{A} and \vec{B} .

ANALYZE Adding the above equations and dividing by 2 leads to $\vec{A} = (1.0)\hat{i} + (4.0)\hat{j}$.

The magnitude of \vec{A} is

$$A = |\vec{A}| = \sqrt{A_x^2 + A_y^2} = \sqrt{(1.0)^2 + (4.0)^2} = 4.1$$

LEARN The vector \vec{B} is $\vec{B} = (5.0)\hat{i} + (-3.0)\hat{j}$, and its magnitude is

$$B = |\vec{B}| = \sqrt{B_x^2 + B_y^2} = \sqrt{(5.0)^2 + (-3.0)^2} = 5.8.$$

The results are summarized in the figure to the right.

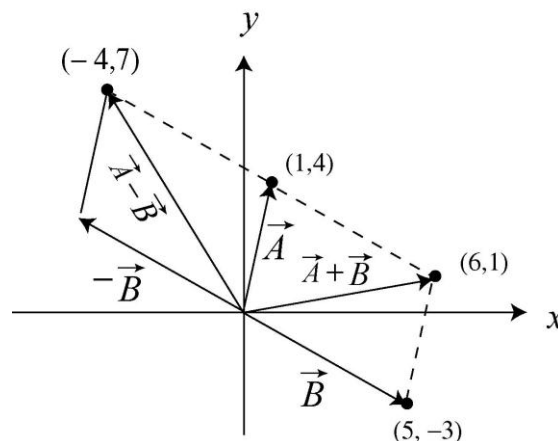

58. The vector can be written as $\vec{d} = (2.5 \text{ m})\hat{j}$, where we have taken \hat{j} to be the unit vector pointing north.

(a) The magnitude of the vector $\vec{a} = 4.0\vec{d}$ is $(4.0)(2.5 \text{ m}) = 10 \text{ m}$.

(b) The direction of the vector $\vec{a} = 4.0\vec{d}$ is the same as the direction of \vec{d} (north).

(c) The magnitude of the vector $\vec{c} = -3.0\vec{d}$ is $(3.0)(2.5 \text{ m}) = 7.5 \text{ m}$.

(d) The direction of the vector $\vec{c} = -3.0\vec{d}$ is the opposite of the direction of \vec{d} . Thus, the direction of \vec{c} is south.

59. Reference to Figure 3-18 (and the accompanying material in that section) is helpful. If we convert \vec{B} to the magnitude-angle notation (as \vec{A} already is) we have $\vec{B} = (14.4 \angle 33.7^\circ)$ (appropriate notation especially if we are using a vector capable calculator in polar mode). Where the length unit is not displayed in the solution, the unit meter should be understood. In the magnitude-angle notation, rotating the axis by $+20^\circ$ amounts to subtracting that angle from the angles previously specified. Thus, $\vec{A} = (12.0 \angle 40.0^\circ)'$ and $\vec{B} = (14.4 \angle 13.7^\circ)'$, where the 'prime' notation indicates that the description is in terms of the new coordinates. Converting these results to (x, y) representations, we obtain

(a) $\vec{A} = (9.19 \text{ m})\hat{i}' + (7.71 \text{ m})\hat{j}'$.

(b) Similarly, $\vec{B} = (14.0 \text{ m}) \hat{i}' + (3.41 \text{ m}) \hat{j}'$.

60. The two vectors can be found by solving the simultaneous equations.

(a) If we add the equations, we obtain $2\vec{a} = 6\vec{c}$, which leads to $\vec{a} = 3\vec{c} = 9\hat{i} + 12\hat{j}$.

(b) Plugging this result back in, we find $\vec{b} = \vec{c} = 3\hat{i} + 4\hat{j}$.

61. The three vectors given are

$$\vec{a} = 5.0 \hat{i} + 4.0 \hat{j} - 6.0 \hat{k}$$

$$\vec{b} = -2.0 \hat{i} + 2.0 \hat{j} + 3.0 \hat{k}$$

$$\vec{c} = 4.0 \hat{i} + 3.0 \hat{j} + 2.0 \hat{k}$$

(a) The vector equation $\vec{r} = \vec{a} - \vec{b} + \vec{c}$ is

$$\begin{aligned} \vec{r} &= [5.0 - (-2.0) + 4.0] \hat{i} + (4.0 - 2.0 + 3.0) \hat{j} + (-6.0 - 3.0 + 2.0) \hat{k} \\ &= 11 \hat{i} + 5.0 \hat{j} - 7.0 \hat{k}. \end{aligned}$$

(b) We find the angle from $+z$ by “dotting” (taking the scalar product) \vec{r} with \hat{k} . Noting that

$$r = |\vec{r}| = \sqrt{(11.0)^2 + (5.0)^2 + (-7.0)^2} = 14,$$

Eq. 3-20 with Eq. 3-23 leads to

$$\vec{r} \cdot \hat{k} = -7.0 = (14)(1) \cos \phi \Rightarrow \phi = 120^\circ.$$

(c) To find the component of a vector in a certain direction, it is efficient to “dot” it (take the scalar product of it) with a unit-vector in that direction. In this case, we make the desired unit-vector by

$$\hat{b} = \frac{\vec{b}}{|\vec{b}|} = \frac{-2.0\hat{i} + 2.0\hat{j} + 3.0\hat{k}}{\sqrt{(-2.0)^2 + (2.0)^2 + (3.0)^2}}.$$

We therefore obtain

$$a_b = \vec{a} \cdot \hat{b} = \frac{(5.0)(-2.0) + (4.0)(2.0) + (-6.0)(3.0)}{\sqrt{(-2.0)^2 + (2.0)^2 + (3.0)^2}} = -4.9.$$

(d) One approach (if all we require is the magnitude) is to use the vector cross product, as the problem suggests; another (which supplies more information) is to subtract the result in part (c) (multiplied by \hat{b}) from \vec{a} . We briefly illustrate both methods. We note that if

$a \cos \theta$ (where θ is the angle between \vec{a} and \vec{b}) gives a_b (the component along \hat{b}) then we expect $a \sin \theta$ to yield the orthogonal component:

$$a \sin \theta = \frac{|\vec{a} \times \vec{b}|}{b} = 7.3$$

(alternatively, one might compute θ from part (c) and proceed more directly). The second method proceeds as follows:

$$\begin{aligned} \vec{a} - a_b \hat{b} &= (5.0 - 2.35)\hat{i} + (4.0 - (-2.35))\hat{j} + ((-6.0) - (-3.53))\hat{k} \\ &= 2.65\hat{i} + 6.35\hat{j} - 2.47\hat{k} \end{aligned}$$

This describes the perpendicular part of \vec{a} completely. To find the magnitude of this part, we compute

$$\sqrt{(2.65)^2 + (6.35)^2 + (-2.47)^2} = 7.3$$

which agrees with the first method.

62. We choose $+x$ east and $+y$ north and measure all angles in the “standard” way (positive ones counterclockwise from $+x$, negative ones clockwise). Thus, vector \vec{d}_1 has magnitude $d_1 = 3.66$ (with the unit meter and three significant figures assumed) and direction $\theta_1 = 90^\circ$. Also, \vec{d}_2 has magnitude $d_2 = 1.83$ and direction $\theta_2 = -45^\circ$, and vector \vec{d}_3 has magnitude $d_3 = 0.91$ and direction $\theta_3 = -135^\circ$. We add the x and y components, respectively:

$$x: d_1 \cos \theta_1 + d_2 \cos \theta_2 + d_3 \cos \theta_3 = 0.65 \text{ m}$$

$$y: d_1 \sin \theta_1 + d_2 \sin \theta_2 + d_3 \sin \theta_3 = 1.7 \text{ m.}$$

(a) The magnitude of the direct displacement (the vector sum $\vec{d}_1 + \vec{d}_2 + \vec{d}_3$) is $\sqrt{(0.65 \text{ m})^2 + (1.7 \text{ m})^2} = 1.8 \text{ m}$.

(b) The angle (understood in the sense described above) is $\tan^{-1}(1.7/0.65) = 69^\circ$. That is, the first putt must aim in the direction 69° north of east.

63. The three vectors are

$$\vec{d}_1 = -3.0\hat{i} + 3.0\hat{j} + 2.0\hat{k}$$

$$\vec{d}_2 = -2.0\hat{i} - 4.0\hat{j} + 2.0\hat{k}$$

$$\vec{d}_3 = 2.0\hat{i} + 3.0\hat{j} + 1.0\hat{k}.$$

(a) Since $\vec{d}_2 + \vec{d}_3 = 0\hat{i} - 1.0\hat{j} + 3.0\hat{k}$, we have

$$\begin{aligned}\vec{d}_1 \cdot (\vec{d}_2 + \vec{d}_3) &= (-3.0\hat{i} + 3.0\hat{j} + 2.0\hat{k}) \cdot (0\hat{i} - 1.0\hat{j} + 3.0\hat{k}) \\ &= 0 - 3.0 + 6.0 = 3.0 \text{ m}^2.\end{aligned}$$

(b) Using Eq. 3-27, we obtain $\vec{d}_2 \times \vec{d}_3 = -10\hat{i} + 6.0\hat{j} + 2.0\hat{k}$. Thus,

$$\begin{aligned}\vec{d}_1 \cdot (\vec{d}_2 \times \vec{d}_3) &= (-3.0\hat{i} + 3.0\hat{j} + 2.0\hat{k}) \cdot (-10\hat{i} + 6.0\hat{j} + 2.0\hat{k}) \\ &= 30 + 18 + 4.0 = 52 \text{ m}^3.\end{aligned}$$

(c) We found $\vec{d}_2 + \vec{d}_3$ in part (a). Use of Eq. 3-27 then leads to

$$\begin{aligned}\vec{d}_1 \times (\vec{d}_2 + \vec{d}_3) &= (-3.0\hat{i} + 3.0\hat{j} + 2.0\hat{k}) \times (0\hat{i} - 1.0\hat{j} + 3.0\hat{k}) \\ &= (11\hat{i} + 9.0\hat{j} + 3.0\hat{k}) \text{ m}^2\end{aligned}$$

64. **THINK** This problem deals with the displacement and distance traveled by a fly from one corner of a room to the diagonally opposite corner. The displacement vector is three-dimensional.

EXPRESS The displacement of the fly is illustrated in the figure below:

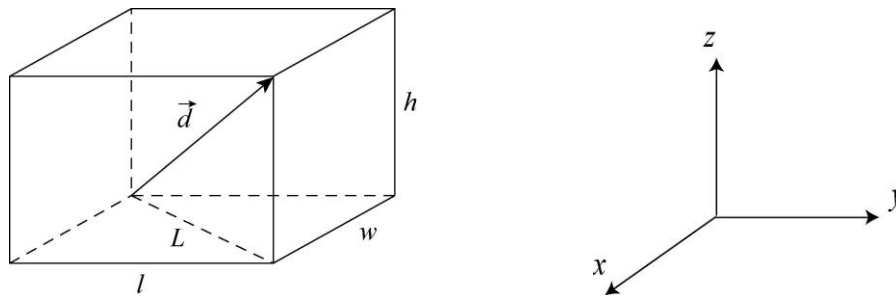

A coordinate system such as the one shown (above right) allows us to express the displacement as a three-dimensional vector.

ANALYZE (a) The magnitude of the displacement from one corner to the diagonally opposite corner is

$$d = |\vec{d}| = \sqrt{w^2 + l^2 + h^2}$$

Substituting the values given, we obtain

$$d = |\vec{d}| = \sqrt{w^2 + l^2 + h^2} = \sqrt{(3.70 \text{ m})^2 + (4.30 \text{ m})^2 + (3.00 \text{ m})^2} = 6.42 \text{ m}.$$

(b) The displacement vector is along the straight line from the beginning to the end point of the trip. Since a straight line is the shortest distance between two points, the length of the path cannot be less than d , the magnitude of the displacement.

(c) The length of the path of the fly can be greater than d , however. The fly might, for example, crawl along the edges of the room. Its displacement would be the same but the path length would be $\ell + w + h = 11.0$ m.

(d) The path length is the same as the magnitude of the displacement if the fly flies along the displacement vector.

(e) We take the x axis to be out of the page, the y axis to be to the right, and the z axis to be upward (as shown in the figure above). Then the x component of the displacement is $w = 3.70$ m, the y component of the displacement is 4.30 m, and the z component is 3.00 m. Thus, the displacement vector can be written as

$$\vec{d} = (3.70 \text{ m})\hat{i} + (4.30 \text{ m})\hat{j} + (3.00 \text{ m})\hat{k}.$$

(f) Suppose the path of the fly is as shown by the dotted lines on the diagram (below left). Pretend there is a hinge where the front wall of the room joins the floor and lay the wall down as shown (above right).

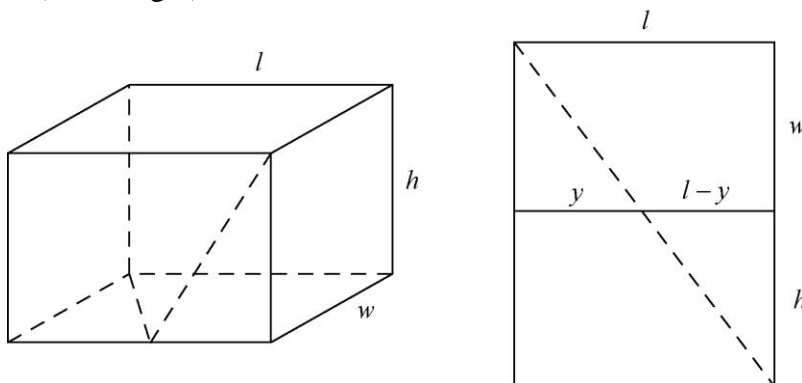

The shortest walking distance between the lower left back of the room and the upper right front corner is the dotted straight line shown on the diagram. Its length is

$$s_{\min} = \sqrt{(w + h)^2 + l^2} = \sqrt{(3.70 \text{ m} + 3.00 \text{ m})^2 + (4.30 \text{ m})^2} = 7.96 \text{ m}.$$

LEARN To show that the shortest path is indeed given by s_{\min} , we write the length of the path as

$$s = \sqrt{y^2 + w^2} + \sqrt{(l - y)^2 + h^2}.$$

The condition for minimum is given by

$$\frac{ds}{dy} = \frac{y}{\sqrt{y^2 + w^2}} - \frac{l-y}{\sqrt{(l-y)^2 + h^2}} = 0.$$

A little algebra shows that the condition is satisfied when $y = lw/(w+h)$, which gives

$$s_{\min} = \sqrt{w^2 \left(1 + \frac{l^2}{(w+h)^2}\right)} + \sqrt{h^2 \left(1 + \frac{l^2}{(w+h)^2}\right)} = \sqrt{(w+h)^2 + l^2}.$$

Any other path would be longer than 7.96 m.

65. (a) This is one example of an answer: $(-40 \hat{i} - 20 \hat{j} + 25 \hat{k})$ m, with \hat{i} directed anti-parallel to the first path, \hat{j} directed anti-parallel to the second path, and \hat{k} directed upward (in order to have a right-handed coordinate system). Other examples include $(40 \hat{i} + 20 \hat{j} + 25 \hat{k})$ m and $(40 \hat{i} - 20 \hat{j} - 25 \hat{k})$ m (with slightly different interpretations for the unit vectors). Note that the product of the components is positive in each example.

(b) Using the Pythagorean theorem, we have $\sqrt{(40 \text{ m})^2 + (20 \text{ m})^2} = 44.7 \text{ m} \approx 45 \text{ m}$.

66. The vectors can be written as $\vec{a} = a\hat{i}$ and $\vec{b} = b\hat{j}$ where $a, b > 0$.

(a) We are asked to consider

$$\frac{\vec{b}}{d} = \left(\frac{b}{d}\right) \hat{j}$$

in the case $d > 0$. Since the coefficient of \hat{j} is positive, then the vector points in the $+y$ direction.

(b) If, however, $d < 0$, then the coefficient is negative and the vector points in the $-y$ direction.

(c) Since $\cos 90^\circ = 0$, then $\vec{a} \cdot \vec{b} = 0$, using Eq. 3-20.

(d) Since \vec{b}/d is along the y axis, then (by the same reasoning as in the previous part) $\vec{a} \cdot (\vec{b}/d) = 0$.

(e) By the right-hand rule, $\vec{a} \times \vec{b}$ points in the $+z$ -direction.

(f) By the same rule, $\vec{b} \times \vec{a}$ points in the $-z$ -direction. We note that $\vec{b} \times \vec{a} = -\vec{a} \times \vec{b}$ is true in this case and quite generally.

(g) Since $\sin 90^\circ = 1$, Eq. 3-24 gives $|\vec{a} \times \vec{b}| = ab$ where a is the magnitude of \vec{a} .

(h) Also, $|\vec{a} \times \vec{b}| = |\vec{b} \times \vec{a}| = ab$.

(i) With $d > 0$, we find that $\vec{a} \times (\vec{b}/d)$ has magnitude ab/d .

(j) The vector $\vec{a} \times (\vec{b}/d)$ points in the $+z$ direction.

67. We note that the set of choices for unit vector directions has correct orientation (for a right-handed coordinate system). Students sometimes confuse “north” with “up”, so it might be necessary to emphasize that these are being treated as the mutually perpendicular directions of our real world, not just some “on the paper” or “on the blackboard” representation of it. Once the terminology is clear, these questions are basic to the definitions of the scalar (dot) and vector (cross) products.

(a) $\hat{i} \cdot \hat{k} = 0$ since $\hat{i} \perp \hat{k}$

(b) $(-\hat{k}) \cdot (-\hat{j}) = 0$ since $\hat{k} \perp \hat{j}$.

(c) $\hat{j} \cdot (-\hat{j}) = -1$.

(d) $\hat{k} \times \hat{j} = -\hat{i}$ (west).

(e) $(-\hat{i}) \times (-\hat{j}) = +\hat{k}$ (upward).

(f) $(-\hat{k}) \times (-\hat{j}) = -\hat{i}$ (west).

68. A sketch of the displacements is shown. The resultant (not shown) would be a straight line from start (Bank) to finish (Walpole). With a careful drawing, one should find that the resultant vector has length 29.5 km at 35° west of south.

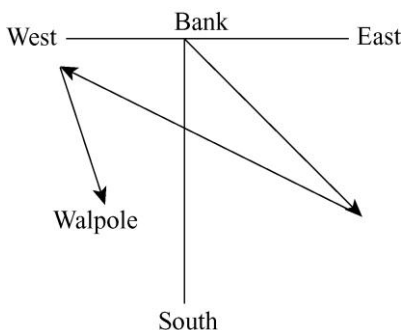

69. The point P is displaced vertically by $2R$, where R is the radius of the wheel. It is displaced horizontally by half the circumference of the wheel, or πR . Since $R = 0.450$ m,

the horizontal component of the displacement is 1.414 m and the vertical component of the displacement is 0.900 m. If the x axis is horizontal and the y axis is vertical, the vector displacement (in meters) is $\vec{r} = (1.414 \hat{i} + 0.900 \hat{j})$. The displacement has a magnitude of

$$|\vec{r}| = \sqrt{(\pi R)^2 + (2R)^2} = R\sqrt{\pi^2 + 4} = 1.68 \text{ m}$$

and an angle of

$$\tan^{-1}\left(\frac{2R}{\pi R}\right) = \tan^{-1}\left(\frac{2}{\pi}\right) = 32.5^\circ$$

above the floor. In physics there are no “exact” measurements, yet that angle computation seemed to yield something *exact*. However, there has to be some uncertainty in the observation that the wheel rolled half of a revolution, which introduces some indefiniteness in our result.

70. The diagram shows the displacement vectors for the two segments of her walk, labeled \vec{A} and \vec{B} , and the total (“final”) displacement vector, labeled \vec{r} . We take east to be the $+x$ direction and north to be the $+y$ direction. We observe that the angle between \vec{A} and the x axis is 60° . Where the units are not explicitly shown, the distances are understood to be in meters. Thus, the components of \vec{A} are $A_x = 250 \cos 60^\circ = 125$ and $A_y = 250 \sin 60^\circ = 216.5$. The components of \vec{B} are $B_x = 175$ and $B_y = 0$. The components of the total displacement are

$$\begin{aligned} r_x &= A_x + B_x = 125 + 175 = 300 \\ r_y &= A_y + B_y = 216.5 + 0 = 216.5. \end{aligned}$$

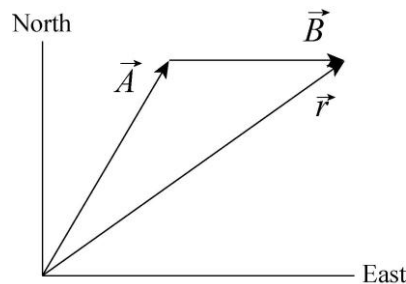

(a) The magnitude of the resultant displacement is

$$|\vec{r}| = \sqrt{r_x^2 + r_y^2} = \sqrt{(300 \text{ m})^2 + (216.5 \text{ m})^2} = 370 \text{ m}.$$

(b) The angle the resultant displacement makes with the $+x$ axis is

$$\tan^{-1}\left(\frac{r_y}{r_x}\right) = \tan^{-1}\left(\frac{216.5 \text{ m}}{300 \text{ m}}\right) = 36^\circ.$$

The direction is 36° north of due east.

(c) The total *distance* walked is $d = 250 \text{ m} + 175 \text{ m} = 425 \text{ m}$.

(d) The total distance walked is greater than the magnitude of the resultant displacement. The diagram shows why: \vec{A} and \vec{B} are not collinear.

71. The vector \vec{d} (measured in meters) can be represented as $\vec{d} = (3.0 \text{ m})(-\hat{j})$, where $-\hat{j}$ is the unit vector pointing south. Therefore, $5.0\vec{d} = 5.0(-3.0 \text{ m } \hat{j}) = (-15 \text{ m})\hat{j}$.

(a) The positive scalar factor (5.0) affects the magnitude but not the direction. The magnitude of $5.0\vec{d}$ is 15 m.

(b) The new direction of $5\vec{d}$ is the same as the old: south.

The vector $-2.0\vec{d}$ can be written as $-2.0\vec{d} = (6.0 \text{ m})\hat{j}$.

(c) The absolute value of the scalar factor ($|-2.0| = 2.0$) affects the magnitude. The new magnitude is 6.0 m.

(d) The minus sign carried by this scalar factor reverses the direction, so the new direction is $+\hat{j}$, or north.

72. The ant's trip consists of three displacements:

$$\vec{d}_1 = (0.40 \text{ m})(\cos 225^\circ \hat{i} + \sin 225^\circ \hat{j}) = (-0.28 \text{ m})\hat{i} + (-0.28 \text{ m})\hat{j}$$

$$\vec{d}_2 = (0.50 \text{ m})\hat{i}$$

$$\vec{d}_3 = (0.60 \text{ m})(\cos 60^\circ \hat{i} + \sin 60^\circ \hat{j}) = (0.30 \text{ m})\hat{i} + (0.52 \text{ m})\hat{j},$$

where the angle is measured with respect to the positive x axis. We have taken the positive x and y directions to correspond to east and north, respectively.

(a) The x component of \vec{d}_1 is $d_{1x} = (0.40 \text{ m})\cos 225^\circ = -0.28 \text{ m}$.

(b) The y component of \vec{d}_1 is $d_{1y} = (0.40 \text{ m})\sin 225^\circ = -0.28 \text{ m}$.

(c) The x component of \vec{d}_2 is $d_{2x} = 0.50 \text{ m}$.

(d) The y component of \vec{d}_2 is $d_{2y} = 0 \text{ m}$.

(e) The x component of \vec{d}_3 is $d_{3x} = (0.60 \text{ m}) \cos 60^\circ = 0.30 \text{ m}$.

(f) The y component of \vec{d}_3 is $d_{3y} = (0.60 \text{ m}) \sin 60^\circ = 0.52 \text{ m}$.

(g) The x component of the net displacement \vec{d}_{net} is

$$d_{\text{net},x} = d_{1x} + d_{2x} + d_{3x} = (-0.28 \text{ m}) + (0.50 \text{ m}) + (0.30 \text{ m}) = 0.52 \text{ m}.$$

(h) The y component of the net displacement \vec{d}_{net} is

$$d_{\text{net},y} = d_{1y} + d_{2y} + d_{3y} = (-0.28 \text{ m}) + (0 \text{ m}) + (0.52 \text{ m}) = 0.24 \text{ m}.$$

(i) The magnitude of the net displacement is

$$d_{\text{net}} = \sqrt{d_{\text{net},x}^2 + d_{\text{net},y}^2} = \sqrt{(0.52 \text{ m})^2 + (0.24 \text{ m})^2} = 0.57 \text{ m}.$$

(j) The direction of the net displacement is

$$\theta = \tan^{-1} \left(\frac{d_{\text{net},y}}{d_{\text{net},x}} \right) = \tan^{-1} \left(\frac{0.24 \text{ m}}{0.52 \text{ m}} \right) = 25^\circ \text{ (north of east)}$$

If the ant has to return directly to the starting point, the displacement would be $-\vec{d}_{\text{net}}$.

(k) The distance the ant has to travel is $|-\vec{d}_{\text{net}}| = 0.57 \text{ m}$.

(l) The direction the ant has to travel is 25° (south of west).

73. We apply Eq. 3-23 and Eq. 3-27.

(a) $\vec{a} \times \vec{b} = (a_x b_y - a_y b_x) \hat{k}$ since all other terms vanish, due to the fact that neither \vec{a} nor \vec{b} have any z components. Consequently, we obtain $((3.0)(4.0) - (5.0)(2.0))\hat{k} = 2.0\hat{k}$.

(b) $\vec{a} \cdot \vec{b} = a_x b_x + a_y b_y$ yields $(3.0)(2.0) + (5.0)(4.0) = 26$.

(c) $\vec{a} + \vec{b} = (3.0 + 2.0)\hat{i} + (5.0 + 4.0)\hat{j} \Rightarrow (\vec{a} + \vec{b}) \cdot \vec{b} = (5.0)(2.0) + (9.0)(4.0) = 46$.

(d) Several approaches are available. In this solution, we will construct a \hat{b} unit-vector and “dot” it (take the scalar product of it) with \vec{a} . In this case, we make the desired unit-vector by

$$\hat{b} = \frac{\vec{b}}{|\vec{b}|} = \frac{2.0 \hat{i} + 4.0 \hat{j}}{\sqrt{(2.0)^2 + (4.0)^2}}.$$

We therefore obtain

$$a_b = \vec{a} \cdot \hat{b} = \frac{(3.0)(2.0) + (5.0)(4.0)}{\sqrt{(2.0)^2 + (4.0)^2}} = 5.81.$$

74. The two vectors \vec{a} and \vec{b} are given by

$$\vec{a} = 3.20(\cos 63^\circ \hat{j} + \sin 63^\circ \hat{k}) = 1.45 \hat{j} + 2.85 \hat{k}$$

$$\vec{b} = 1.40(\cos 48^\circ \hat{i} + \sin 48^\circ \hat{k}) = 0.937 \hat{i} + 1.04 \hat{k}$$

The components of \vec{a} are $a_x = 0$, $a_y = 3.20 \cos 63^\circ = 1.45$, and $a_z = 3.20 \sin 63^\circ = 2.85$.

The components of \vec{b} are $b_x = 1.40 \cos 48^\circ = 0.937$, $b_y = 0$, and $b_z = 1.40 \sin 48^\circ = 1.04$.

(a) The scalar (dot) product is therefore

$$\vec{a} \cdot \vec{b} = a_x b_x + a_y b_y + a_z b_z = (0)(0.937) + (1.45)(0) + (2.85)(1.04) = 2.97.$$

(b) The vector (cross) product is

$$\begin{aligned} \vec{a} \times \vec{b} &= (a_y b_z - a_z b_y) \hat{i} + (a_z b_x - a_x b_z) \hat{j} + (a_x b_y - a_y b_x) \hat{k} \\ &= ((1.45)(1.04) - 0) \hat{i} + ((2.85)(0.937) - 0) \hat{j} + (0 - (1.45)(0.937)) \hat{k} \\ &= 1.51 \hat{i} + 2.67 \hat{j} - 1.36 \hat{k}. \end{aligned}$$

(c) The angle θ between \vec{a} and \vec{b} is given by

$$\theta = \cos^{-1} \left(\frac{\vec{a} \cdot \vec{b}}{ab} \right) = \cos^{-1} \left(\frac{2.97}{(3.20)(1.40)} \right) = 48.5^\circ.$$

75. We orient \hat{i} eastward, \hat{j} northward, and \hat{k} upward, and use the following fundamental products:

$$\begin{aligned} \hat{i} \times \hat{j} &= -\hat{j} \times \hat{i} = \hat{k} \\ \hat{j} \times \hat{k} &= -\hat{k} \times \hat{j} = \hat{i} \\ \hat{k} \times \hat{i} &= -\hat{i} \times \hat{k} = \hat{j} \end{aligned}$$

(a) “north cross west” = $\hat{j} \times (-\hat{i}) = \hat{k}$ = “up.”

(b) “down dot south” = $(-\hat{k}) \cdot (-\hat{j}) = 0$.

(c) “east cross up” = $\hat{i} \times (\hat{k}) = -\hat{j}$ = “south.”

(d) “west dot west” = $(-\hat{i}) \cdot (-\hat{i}) = 1$.

(e) “south cross south” = $(-\hat{j}) \times (-\hat{j}) = 0$.

76. Let A denote the magnitude of \vec{A} ; similarly for the other vectors. The vector equation is $\vec{A} + \vec{B} = \vec{C}$ where $B = 8.0$ m and $C = 2A$. We are also told that the angle (measured in the ‘standard’ sense) for \vec{A} is 0° and the angle for \vec{C} is 90° , which makes this a right triangle (when drawn in a “head-to-tail” fashion) where B is the size of the hypotenuse. Using the Pythagorean theorem,

$$B = \sqrt{A^2 + C^2} \Rightarrow 8.0 = \sqrt{A^2 + 4A^2}$$

which leads to $A = 8/\sqrt{5} = 3.6$ m.

77. We orient \hat{i} eastward, \hat{j} northward, and \hat{k} upward.

(a) The displacement is $\vec{d} = (1300 \text{ m})\hat{i} + (2200 \text{ m})\hat{j} + (-410 \text{ m})\hat{k}$.

(b) The displacement for the return portion is $\vec{d}' = -(1300 \text{ m})\hat{i} - (2200 \text{ m})\hat{j}$ and the magnitude is $d' = \sqrt{(-1300 \text{ m})^2 + (-2200 \text{ m})^2} = 2.56 \times 10^3 \text{ m}$.

The net displacement is zero since his final position matches his initial position.

78. Let $\vec{c} = \vec{b} \times \vec{a}$. Then the magnitude of \vec{c} is $c = ab \sin \phi$. Since \vec{c} is perpendicular to \vec{a} the magnitude of $\vec{a} \times \vec{c}$ is ac . The magnitude of $\vec{a} \times (\vec{b} \times \vec{a})$ is consequently

$$|\vec{a} \times (\vec{b} \times \vec{a})| = ac = a^2 b \sin \phi.$$

Substituting the values given, we obtain

$$|\vec{a} \times (\vec{b} \times \vec{a})| = a^2 b \sin \phi = (3.90)^2 (2.70) \sin 63.0^\circ = 36.6.$$

79. The area of a triangle is half the product of its base and altitude. The base is the side formed by vector \vec{a} . Then the altitude is $b \sin \phi$ and the area is $A = \frac{1}{2} ab \sin \phi = \frac{1}{2} |\vec{a} \times \vec{b}|$.

Substituting the values given, we have

$$A = \frac{1}{2} ab \sin \phi = \frac{1}{2} (4.3)(5.4) \sin 46^\circ \approx 8.4.$$